

WE BRING
THE TECHNOLOGY
OF THE FUTURE
TO THE PRESENT



YÜK VAGONLARI
FREIGHT WAGONS



T.C. ULAŞTIRMA VE
ALTYAPI BAKANLIĞI

TURASAS

**WE BRING THE TECHNOLOGY
OF THE FUTURE TO THE PRESENT**

**GELECEĐİN TEKNOLOJİSİNİ
GÜNÜMÜZE TAŞIYORUZ.**

www.turasas.gov.tr

TURASAS

ABOUT US

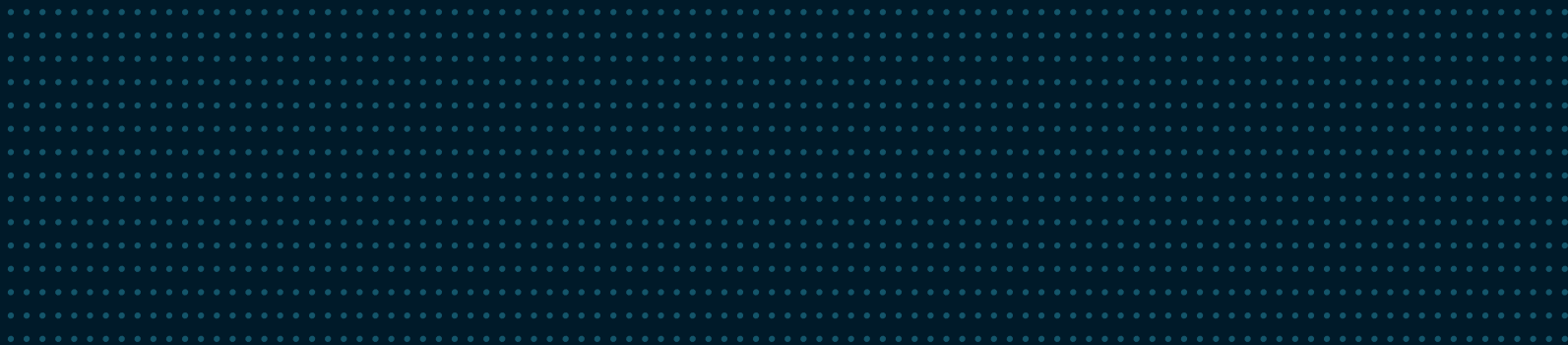

About TÜRASAŞ

TÜRASAŞ, A global leader in its region...

TÜRASAŞ, with its experience and know-how of more than a century in the railway sector, over 4.000 employees and facilities located in 3 different cities making production with latest technology for both domestic and international market in an area of 1.4 million, 400 thousand m2 of which is indoor, is the largest representative of the Rail Systems Sector in our country.

Having a deep-rooted corporate culture with its stakeholders, TÜRASAŞ aspires to improve this culture by following three megatrends which shapes the mobility environment: digitalisation, climate change and population growth. In the changing and developing mobility environment, TÜRASAŞ is aware of what it takes to follow these trends: sustainable, reliable and secure mobility solutions to assure a higher quality of life for billions of people worldwide, who will aspire for seamless transportation from first to last kilometre. Digitalisation make our job easier in mastering these trends and continuously transform the way we travel.

Sustainable railway technologies for future generations

Our understanding of sustainability is fully based on TURASAS' company values- responsibility, excellence and innovation. We see the sustainable development as the means to achieve profitable and long-term growth. With our sustainable solutions, we help our customers have a competitive advantage. We promote the safety, education and well-being of our employees. While doing all these, we always keep the respect for nature in our minds by following more environmentally friendly manufacturing methods.

Being aware that we can only build tomorrow from today, we carry out our work at TÜRASAŞ. Every work done targets tomorrow rather than today. We take care that the steps we take in every field, from the quality of our products to the improvement of working conditions, from the collaborations established to the correct communication strategy, are the steps that will carry TÜRASAŞ to the future.

Today, as TÜRASAŞ, we look at the world from the threshold of a bright future and we see that it must always be more advanced than the point we look at. TÜRASAŞ has undertaken an important mission in order to reach wider segments with its technology-intensive production and to maintain stable growth by following the sectoral developments closely with its innovative perspective.

TÜRASAŞ Hakkında

Bölgesinde Küresel Bir Lider TÜRASAŞ...

TÜRASAŞ, Demiryolu sektöründe bir asrı aşan tecrübe ve bilgi birikimi, 4 bini aşkın çalışanı, 3 farklı şehirde bulunan 400 bin metrekaresi kapalı olmak üzere 1.4 milyon metrekaare alanda en son teknoloji ile hem yurt içi hem de uluslararası pazar için üretim yapan ülkemizdeki Raylı Sistem Sektörünün en büyük temsilcisidir

Paydaşları ile birlikte köklü bir kurum kültürüne sahip olan TÜRASAŞ bu kültürünü ulaşım ekosistemini şekillendiren üç mega trendi takip ederek geliştirmeyi hedeflemektedir: Dijitalleşme, iklim değişikliği ve nüfus artışı. Değişen ve gelişen ulaşım ekosisteminde TÜRASAŞ bu trendleri takip etmenin neler gerektirdiğinin farkındadır: dünya çapındaki milyarlarca insanın daha yüksek yaşam kalitesini temin edecek sürdürülebilir, güvenilir ve emniyetli ulaşım çözümleri. Dijitalleşme bu trenlerde ustalaşmamızı kolaylaştırmakta ve sürekli olarak seyahat etme şeklimizi dönüştürmektedir.

Gelecek nesiller için sürdürülebilir demiryolu teknolojileri...

Sürdürülebilirlik anlayışımız tamamen TÜRASAŞ'ın köklü şirket değerlerine dayanmaktadır- sorumluluk, mükemmellik ve inovasyon. Sürdürülebilir kalkınmayı karlı ve uzun vadeli büyüme elde etmenin aracı olarak görmekteyiz. Sürdürülebilir çözümlerimizle, müşterilerimize rekabet avantajı sağlamaktayız. Çalışanlarımızın güvence, eğitim ve refahını artırmaktayız. Tüm bunları yaparken de daha çevre dostu üretim metodlarını takip ederek doğaya olan saygımızı hiç aklımızdan çıkarmıyoruz.

Yarınları ancak bugünden inşa edebileceğimizin farkında olarak, TÜRASAŞ' ta çalışmalarımızı yürütmekteyiz. Yapılan her çalışma, bugünden çok yarınları hedef almaktadır. Ürünlerimizin niteliğinden çalışma koşullarının iyileştirilmesine, kurulan işbirliklerinden doğru iletişim stratejisine kadar her alanda attığımız adımların TÜRASAŞ' ı yarınlara taşıyacak adımlar olmasına dikkat etmekteyiz.

Bugün TÜRASAŞ olarak, aydınlık bir geleceğin eşiğinden bakıyoruz dünyaya ve baktığımız noktadan hep daha ileri olması gerektiğini görüyoruz. TÜRASAŞ, yenilikçi bakış açısıyla, sektörel gelişmeleri yakından takip ederek, teknoloji yoğun üretimleriyle daha geniş kesimlere ulaşması ve istikrarlı büyümenin devamlılığı adına önemli bir misyon üstlenmiştir.

Güçlerin birleştirilmesi...

TÜRASAŞ, kendi alanlarında Türkiye'nin en büyük demiryolu araç üreticileri olan TÜDEMSAŞ, TÜLOMSAŞ ve TÜVASAŞ şirketlerinin tek çatı altında birleştirilmesi ile kurulmuş ve bölgesinin en büyük raylı sistem araçları üreticisi haline gelerek

Combining our forces.

TÜRASAŞ was founded by gathering of TÜDEMSAŞ, TÜLOMSAŞ and TÜVASAŞ, Turkey's the largest railway vehicles manufacturers in their fields, under a single roof and increased its established LOADING CAPACITY as to allow itself to utilise it more efficiently and became the largest rail system vehicles manufacturers in its region. TÜRASAŞ performs its duty of umbrella organisation for all companies in railway sector successfully by designing railway vehicles and critical sub-systems through local LOADING CAPACITY and manufacturing them in cooperation with local suppliers. As today, it aims to meet railway vehicle and critical sub-system needs of domestic and international market by leading local eco-system for the future as well. This new structure operates with a mentality that takes into account the sector and the public interest as well as the profit goal.

The most important visional goal of our company, which produces such main and sub-products such as

New Generation Locomotives,
Diesel and Electric Train Sets,
Passenger coaches
Freight Wagons,

and critical sub-systems of them

Bogies for passenger coaches and freight wagons
Traction Converter
Traction Engine
Diesel Engine
TCMS

in international standards, is to have a say in the sector with new generation products bearing its own brand not only in our country but also in the international arena.

National High Speed Train being in the first place, we continue our efforts to meet the demands in the design and manufacture of domestic and national Metro, Tram and Commuter vehicles for inner-city transportation.

Our projects for various types of railway vehicles, critical sub-systems of them and TSI certified locomotives, passenger coaches and freight wagons with TÜRASAŞ brand to meet the needs of domestic and international market are in progress. Our aim is to increase the added value of our products and to become an R&D focused company needed by the sector by supporting railway industry. For our customers, we continuously innovating our portfolio with efficient and quality products having smart transportation systems.

kurulu kapasitesini daha etkin bir şekilde kullanmasına imkân verecek şekilde arttırmıştır. Şirket, ülkemizin ve bölgemizin ihtiyacı olarak demiryolu araçları ve kritik alt sistemlerini milli ve yerli olarak tasarlayıp üretimini yerli tedarikçileri ile birlikte gerçekleştirerek demiryolu sektöründe yer alan tüm firmalar için bir çatı kuruluş görevini başarıyla yerine getirmektedir. Gelecek dönem için de yine yerli ekosisteme liderlik ederek yurt içi ve yurt dışı demiryolu araç ve kritik alt sistem ihtiyacını karşılamayı hedeflemektedir.

Bu yeni yapı, kar amacı yanında, sektör ve kamu yararını da gözetten bir zihniyetle çalışmaktadır.

Raylı Sistem Araçları Sektöründe bugüne kadar uluslararası standartlarda;

- * Yeni Nesil Lokomotifler,
- * Dizel ve Elektrikli Tren Setleri,
- * Yolcu Vagonları
- * Yük Vagonları

ve bunlara ait kritik alt sistemler

- *Yolcu ve Yük Vagon Bojileri
- * Cer konvertörü,
- * Cer motoru,
- * Dizel Motor,
- * TCMS

gibi ana ve alt ürünleri üreten Şirketimizin en önemli vizyonel hedefi ise sadece ülkemizde değil uluslararası alanda da kendi markasını taşıyan yeni nesil ürünlerle sektörde söz sahibi olmaktır.

Milli Yüksek Hızlı Tren başta olmak üzere, Kent içi ulaşım için yerli ve milli Metro, Tramvay ve Banliyö araçlarının tasarımı ve imalatında talepleri karşılamak için çalışmalarımızı sürdürüyoruz. Yurtiçi-yurtdışı pazar ihtiyacını karşılayabilecek çeşitli tipte TÜRASAŞ marka her türlü demiryolu aracı, demiryolu aracı kritik alt sistemleri ile TSI sertifikalı lokomotif, yük ve yolcu vagonu projeleri devam etmektedir.

Amacımız; demiryolu endüstrisine güç vererek ürünlerimizin katma değerini arttırmak ve sektörün ihtiyacı olan Ar-Ge odaklı bir şirket olmaktır. Müşterilerimiz için akıllı ulaşım sistemlerine sahip, verimli ve kaliteli ürünler ile portföyümüzü sürekli yenilemekteyiz.



NATIONAL AND DOMESTIC PRODUCTION

MİLLİ ve YERLİ ÜRETİM



Sgmmns(s) TYPE 40 CONTAINER WAGON

Sgmmns TİPİ 40' KONTEYNER VAGONU



*Minimum tara ve vagon uzunluğu ile maksimum yük taşımaya uygun bir tasarıma sahip olan 4 akslı Sgmmns 40' vagon, 20', 30' ve 40' konteynerlerin taşınması için uygundur.

*Vagon tasarımı ve üretimi TSI, EN, UIC standartlarının gereksinimlerini karşılar ve TEN GE trafiğine uygundur. vagonudur.

*The 4-axle Sgmmns 40' wagon, which has minimum tare and wagon length and maximum load carrying capacity, is suitable for 20',30' and 40' containers.

*The wagon design and manufacturing meets the requirements of TSI, EN, UIC standards and has TEN GE marking for traffic operation.

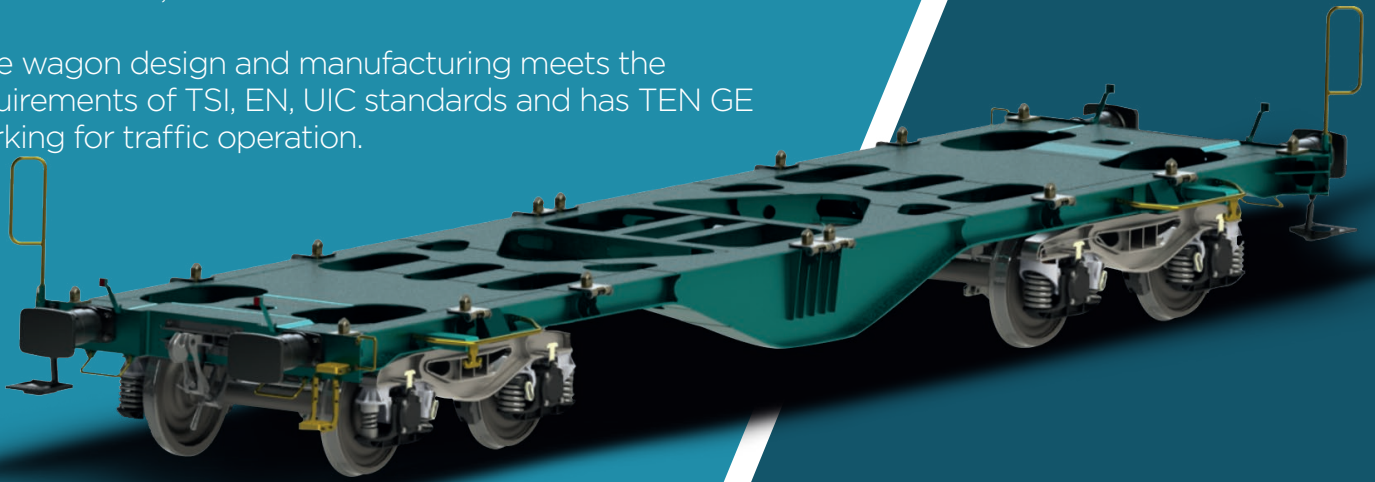

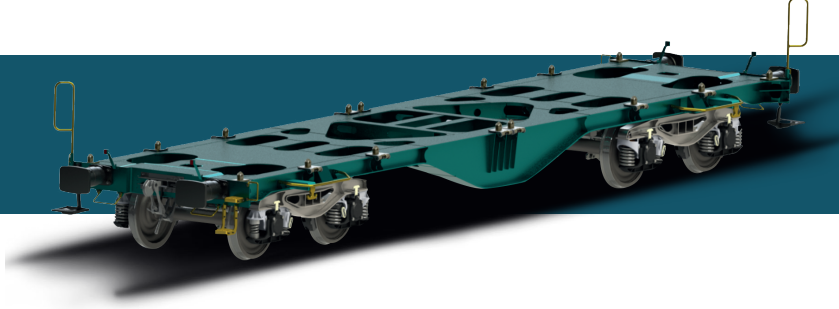

Sgmmns TYPE 40



Teknik Özellikler

| | |
|-----------------------------|--------------|
| RAY AÇIKLIĞI | 1435 mm |
| DARA AĞIRLIĞI | 16 t |
| YÜKLEME KAPASİTESİ | 74 t |
| TOPLAM AĞIRLIĞI | 90 t |
| VAGON BOYU | 12250 mm |
| VAGON GENİŞLİĞİ | 2950 mm |
| PLATFORM YÜKSEKLİĞİ | 1135 mm |
| TAMPONDAN TAMPONA UZUNLUK | 13490 mm |
| BOJİ EKSENLERİ ARASI MESAFE | 8450 mm |
| BOJİ TİPİ | Y25Ls(s)d1-K |

Technical Characteristics

| | |
|--------------------------------|--------------|
| TRACK GAUGE | 1435 mm |
| TARE WEIGHT WEIGHT | 16 t |
| LOADING LOADING CAPACITY | 74 t |
| TOTAL WEIGHT | 90 t |
| LENGTH OF WAGON | 12250 mm |
| WIDTH OF WAGON | 2950 mm |
| HEIGHT OF WAGON | 1135 mm |
| LENGTH OVER BUFFERS | 13490 mm |
| DISTANCE BETWEEN BOGIE CENTERS | 8450 mm |
| BOGIE TYPE | Y25Ls(s)d1-K |

Sgmmns(s) TYPE 45 CONTAINER WAGON

Sgmmns TİPİ 45' KONTEYNER VAGONU



*Minimum tara ve vagon uzunluğu ile maksimum yük taşımaya uygun bir tasarıma sahip olan 4 akslı Sgmmns 40' vagon, 20', 30', 40' ve 45' konteynerlerin taşınması için uygundur.

*Vagon tasarımı ve üretimi TSI, EN, UIC standartlarının gereksinimlerini karşılar ve TEN GE trafiğine uygundur.

*The 4-axle Sgmmns 45' wagon, which has minimum tare and wagon length and maximum load carrying capacity, is suitable for 20', 30', 40' and 45' containers.

*The wagon design and manufacturing meets the requirements of TSI, EN, UIC standards and has TEN GE marking for traffic operation.





Sgmmns TYPE 45



Teknik Özellikler

| | |
|-----------------------------|-------------|
| RAY AÇIKLIĞI | 1435 mm |
| DARA AĞIRLIĞI | 16,85 t |
| YÜKLEME KAPASİTESİ | 73,15 t |
| TOPLAM AĞIRLIĞI | 90 t |
| VAGON BOYU | 14400 mm |
| VAGON GENİŞLİĞİ | 2975 mm |
| PLATFORM YÜKSEKLİĞİ | 1155 mm |
| TAMPONDAN TAMPONA UZUNLUK | 15640 mm |
| BOJİ EKSENLERİ ARASI MESAFE | 10600 mm |
| BOJİ TİPİ | Y25Ls(s)1-K |

Technical Characteristics

| | |
|--------------------------------|-------------|
| TRACK GAUGE | 1435 mm |
| TARE WEIGHT WEIGHT | 16,85 t |
| LOADING LOADING CAPACITY | 73,15 t |
| TOTAL WEIGHT | 90 t |
| LENGTH OF WAGON | 14400 mm |
| WIDTH OF WAGON | 2975 mm |
| HEIGHT OF WAGON | 1155 mm |
| LENGTH OVER BUFFERS | 15640 mm |
| DISTANCE BETWEEN BOGIE CENTERS | 10600 mm |
| BOGIE TYPE | Y25Ls(s)1-K |

Sggmrs TYPE 90 NEW GENERATION PLATFORM WAGON

Sggmrs 90' PLATFORM TİPİ YENİ NESİL MİLLİ YÜK VAGONU



*6 akslı üç bojlili, mafsallı iki platformlu intermodal vagon, 20' , 30' , 40' ve 45' konteynerlerin taşınmasına uygundur.

*Vagon tasarımı ve üretimi TSI, EN, UIC standartlarının gereksinimlerini karşılar ve TEN GE trafiğine uygundur.

*The articulated two platforms intermodal wagon with three bogies 6-axle is suitable for the transportation of 20' , 30' , 40' and 45' containers.

*The wagon design and manufacturing meets the requirements of TSI, EN, UIC standards and has TEN GE marking for traffic operation.

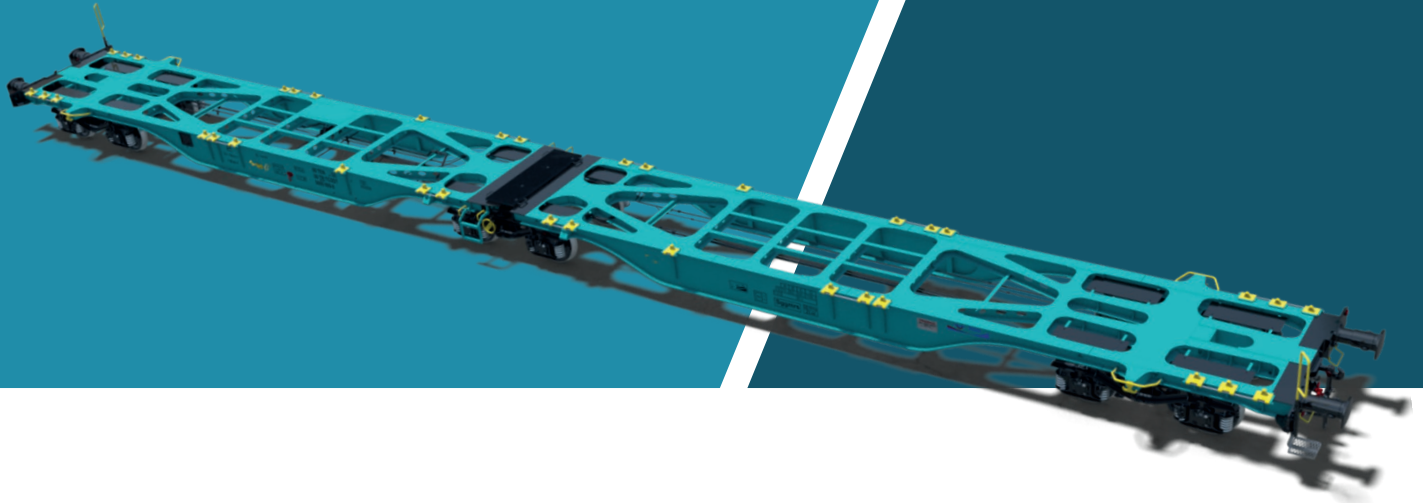

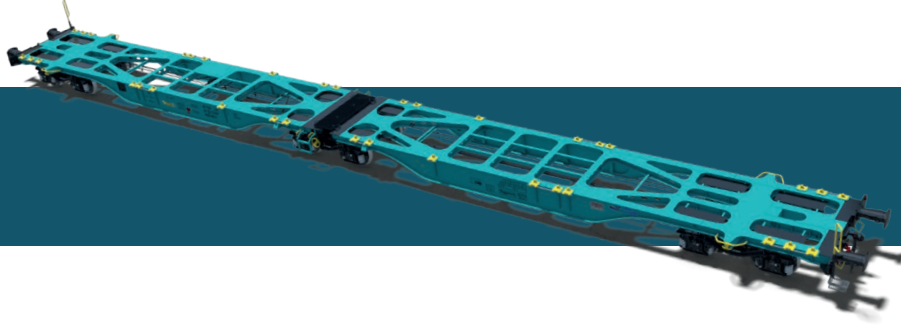

Sggmrs TYPE 90



Teknik Özellikler

| | |
|-----------------------------|----------------|
| RAY AÇIKLIĞI | 1435 mm |
| DARA AĞIRLIĞI | 25,5 t |
| YÜKLEME KAPASİTESİ | 109,5 t |
| TOPLAM AĞIRLIĞI | 135 t |
| VAGON BOYU | 28350 mm |
| VAGON GENİŞLİĞİ | 3135 mm |
| PLATFORM YÜKSEKLİĞİ | 1155 mm |
| TAMPONDAN TAMPONA UZUNLUK | 29590 mm |
| BOJİ EKSENLERİ ARASI MESAFE | 11995 mm |
| BOJİ TİPİ | Y25Lsdı(f)-KC1 |

Technical Characteristics

| | |
|--------------------------------|----------------|
| TRACK GAUGE | 1435 mm |
| TARE WEIGHT WEIGHT | 25,5 t |
| LOADING LOADING CAPACITY | 109,5 t |
| TOTAL WEIGHT | 135 t |
| LENGTH OF WAGON | 28350 mm |
| WIDTH OF WAGON | 3135 mm |
| HEIGHT OF WAGON | 1155 mm |
| LENGTH OVER BUFFERS | 29590 mm |
| DISTANCE BETWEEN BOGIE CENTERS | 11995 mm |
| BOGIE TYPE | Y25Lsdı(f)-KC1 |

Rgns TYPE 60 CONTAINER PLATFORM WAGON

Rgns TİPİ 60' KONTEYNER PLATFORM VAGONU



*Yapısal dayanım-dara optimizasyonu yaklaşımı ile tasarlanan ve üretilen vagon, 19,9 ton ile Türkiye ve Avrupa'nın en hafif daraya sahip Rgns Tipi Konteyner Platform vagonu olma özelliğini taşımaktadır. Metalürjik ürünlerin (çelik borular, profiller, tabakalar), taşıtlar, hafif raylı araçlar ve konteynerlerin taşınmasına uygundur.

*Vagon tasarımı ve üretimi TSI, EN, UIC standartlarının gereksinimlerini karşılar ve TEN GE trafiğine uygundur.

*Designed and manufactured with the structural strength-tare optimization approach, the wagon is the Rgns Type Container Platform wagon with the lightest tare in Turkey and Europe with 19.9 tons. It is suitable for transport of metallurgical products (steel tubes, profiles, plates), wheeled vehicles, light track vehicles and containers.

*The wagon design and manufacturing meets the requirements of TSI, EN, UIC standards and has TEN GE marking for traffic operation.





Rgns TYPE 60



Teknik Özellikler

| | |
|-----------------------------|---------------------------|
| RAY AÇIKLIĞI | 1435 mm |
| DARA AĞIRLIĞI | 19,9 t |
| YÜKLEME KAPASİTESİ | 70,1 t |
| TOPLAM AĞIRLIĞI | 90 t |
| YÜKLEME YÜKLEME ALANI | 49,31 m ² |
| VAGON BOYU | 18400 mm |
| VAGON GENİŞLİĞİ | 2640 mm |
| PLATFORM YÜKSEKLİĞİ | 1230 mm |
| TAMPONDAN TAMPONA UZUNLUK | 19640 mm |
| BOJİ EKSENLERİ ARASI MESAFE | 14100 mm |
| BOJİ TİPİ | Y25Lsdı(f)-K / Y25Lsd-KP1 |

Technical Characteristics

| | |
|--------------------------------|---------------------------|
| TRACK GAUGE | 1435 mm |
| TARE WEIGHT WEIGHT | 19,9 t |
| LOADING LOADING CAPACITY | 70,1 t |
| TOTAL WEIGHT | 90 t |
| LOADING LOADING SURFACE | 49,31 m ² |
| LENGTH OF WAGON | 18400 mm |
| WIDTH OF WAGON | 2640 mm |
| HEIGHT OF WAGON | 1230 mm |
| LENGTH OVER BUFFERS | 19640 mm |
| DISTANCE BETWEEN BOGIE CENTERS | 14100 mm |
| BOGIE TYPE | Y25Lsdı(f)-K / Y25Lsd-KP1 |

Rgns TYPE 60 PLATFORM WAGON

Rgns TİPİ 60' PLATFORM VAGON



*Çeşitli tipte konteynerler (20', 30', 40') ve yayılı yük taşımaya uygun olarak tasarlanan ve üretilen Rgns Tipi Konteyner Platform Vagonu; TSI, EN, UIC standartlarının gereksinimlerini karşılar ve TEN GE trafiğine uygundur.

*Designed and manufactured for carrying various type of containers (20', 30' and 40') and distributed load, Rgns Type Container Platform Wagon meets the requirements of TSI, EN, UIC standards and has TEN GE marking for traffic operation.

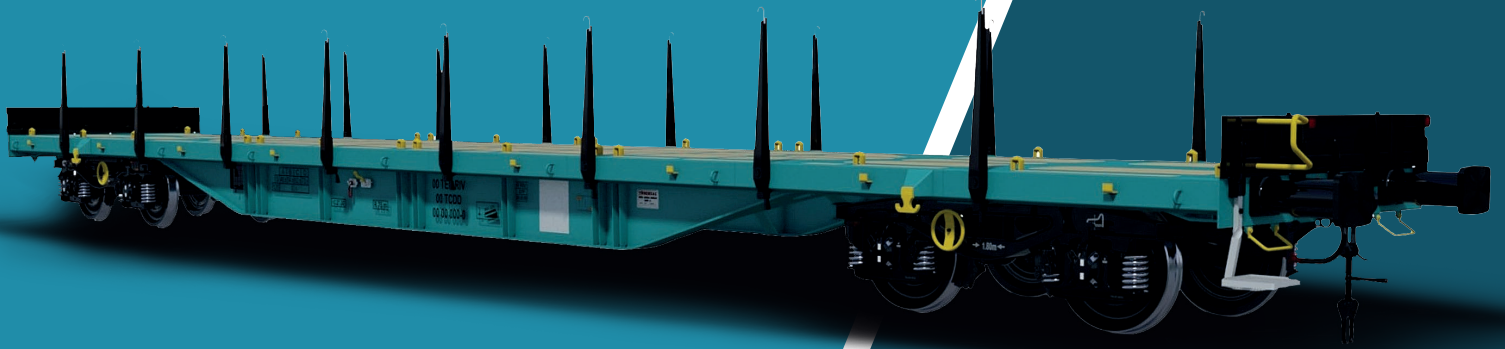

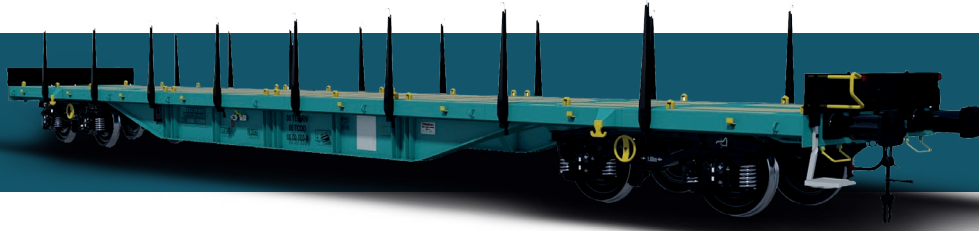

Rgns TYPE 60



Teknik Özellikler

| | |
|---------------------------|-------------------|
| RAY AÇIKLIĞI | 1435 mm |
| DARA AĞIRLIĞI | 20,9 t |
| YÜKLEME KAPASİTESİ | 69,1 t |
| TOPLAM AĞIRLIĞI | 90 t |
| YÜKLEME ALANI | 51 m ² |
| VAGON BOYU | 18400 mm |
| VAGON GENİŞLİĞİ | 2912 mm |
| PLATFORM YÜKSEKLİĞİ | 1150 mm |
| TAMPONDAN TAMPONA UZUNLUK | 19640 mm |
| BOJİ EKSENLERİ ARASI | 14200 mm |
| BOJİ TİPİ | Y25Lsd(f)-KC1 |

Technical Characteristics

| | |
|--------------------------------|-------------------|
| TRACK GAUGE | 1435 mm |
| TARE WEIGHT | 20,9 t |
| LOADING CAPACITY | 69,1 t |
| TOTAL WEIGHT | 90 t |
| LOADING SURFACE | 51 m ² |
| LENGTH OF WAGON | 18400 mm |
| WIDTH OF WAGON | 2912 mm |
| HEIGHT OF WAGON | 1150 mm |
| LENGTH OVER BUFFERS | 19640 mm |
| DISTANCE BETWEEN BOGIE CENTERS | 14200 mm |
| BOGIE TYPE | Y25Lsd(f)-KC1 |

Sgns TYPE 60 CONTAINER WAGON

Sgns TİPİ 60' KONTEYNER VAGONU



*Minimum tara ve vagon uzunluğu ile maksimum yük taşımaya uygun bir tasarıma sahip olan 4 akslı Sgns 60' vagon, 20', 30' ve 40' konteynerlerin taşınması için uygundur.

*Vagon tasarımı ve üretimi TSI, EN, UIC standartlarının gereksinimlerini karşılar ve TEN GE trafiğine uygundur.

*The 4-axle Sgmmns 45' wagon, which has minimum tare and wagon length and maximum load carrying capacity, is suitable for 20', 30' and 40' containers.

*The wagon design and manufacturing meets the requirements of TSI, EN, UIC standards and has TEN GE marking for traffic operation.

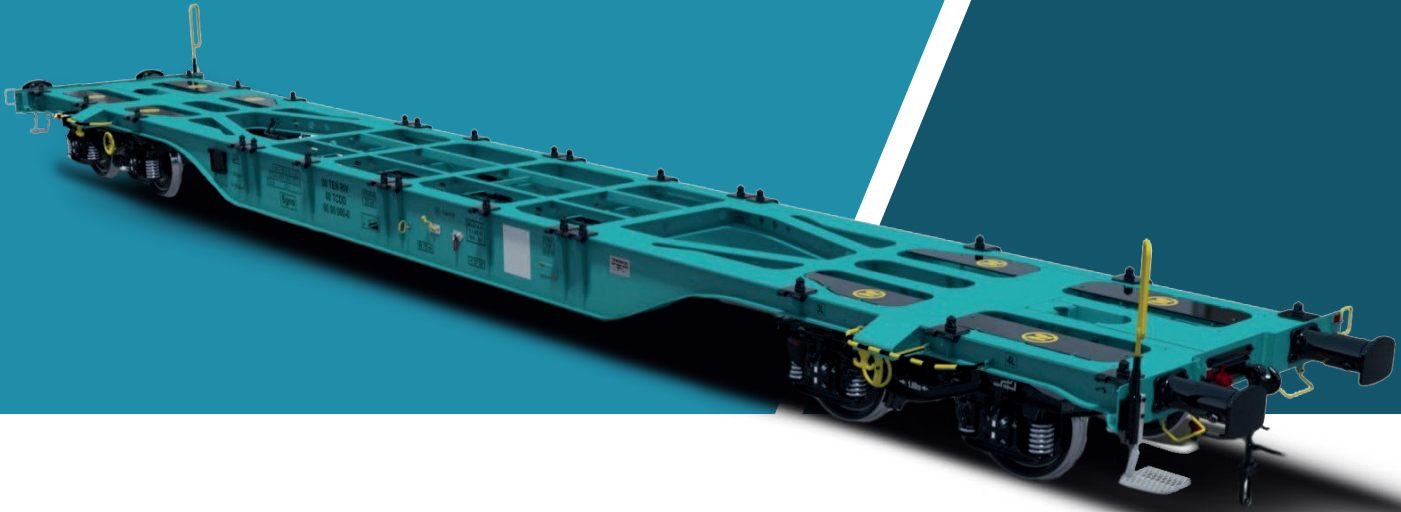

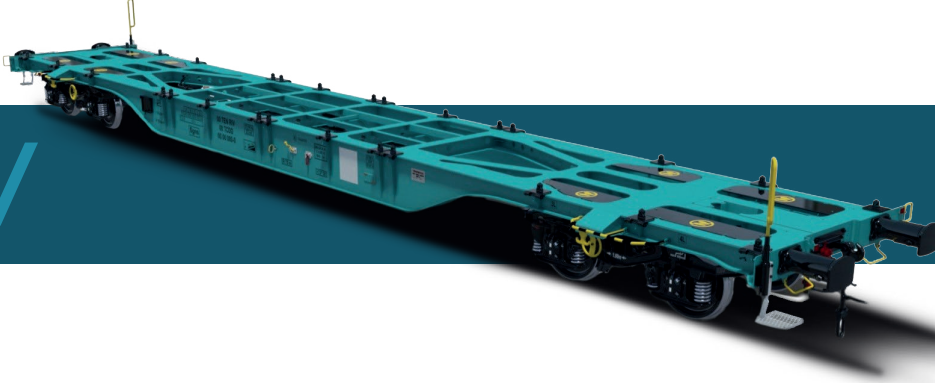

Sgns TYPE 60



Teknik Özellikler

| | |
|---------------------------|---------------|
| RAY AÇIKLIĞI | 1435 mm |
| DARA AĞIRLIĞI | 17,25 t |
| YÜKLEME KAPASİTESİ | 72,75 t |
| TOPLAM AĞIRLIĞI | 90 t |
| VAGON BOYU | 18500 mm |
| VAGON GENİŞLİĞİ | 3130 mm |
| PLATFORM YÜKSEKLİĞİ | 1162 mm |
| TAMPONDAN TAMPONA UZUNLUK | 19740 mm |
| BOJİ EKSENLERİ ARASI | 14200 mm |
| BOJİ TİPİ | Y25Lsd(f)-KC1 |

Technical Characteristics

| | |
|--------------------------------|---------------|
| TRACK GAUGE | 1435 mm |
| TARE WEIGHT | 17,25 t |
| LOADING CAPACITY | 72,75 t |
| TOTAL WEIGHT | 90 t |
| LENGTH OF WAGON | 18500 mm |
| WIDTH OF WAGON | 3130 mm |
| HEIGHT OF WAGON | 1162 mm |
| LENGTH OVER BUFFERS | 19740 mm |
| DISTANCE BETWEEN BOGIE CENTERS | 14200 mm |
| BOGIE TYPE | Y25Lsd(f)-KC1 |

Sggrs(s) TYPE 80 CONTAINER WAGON

Sggrs(s) TİPİ 80' KONTEYNER VAGONU



*6 akslı üç bojili, mafsallı iki platformlu intermodal vagon, 20' , 30' ve 40' konteynerlerin taşınmasına uygundur.

*Vagon tasarımı ve üretimi TSI, EN, UIC standartlarının gereksinimlerini karşılar ve TEN GE trafiğine uygundur.

*The articulated two platforms intermodal wagon with three bogies 6-axle is suitable for the transportation of 20' , 30' and 40' containers.

*The wagon design and manufacturing meets the requirements of TSI, EN, UIC standards and has TEN GE marking for traffic operation.



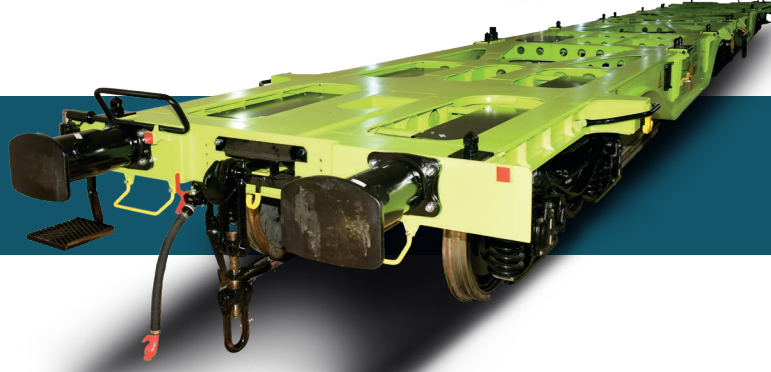

Sggrs (s) TYPE 80



Teknik Özellikler

| | |
|-----------------------------|---------------------------------|
| RAY AÇIKLIĞI | 1435 mm |
| DARA AĞIRLIĞI | 24,7 t |
| YÜKLEME KAPASİTESİ | 110,3 t |
| TOPLAM AĞIRLIĞI | 135 t |
| VAGON BOYU | 25150 mm |
| VAGON GENİŞLİĞİ | 3135 mm |
| PLATFORM YÜKSEKLİĞİ | 1135 mm |
| TAMPONDAN TAMPONA UZUNLUK | 26390 mm |
| BOJİ EKSENLERİ ARASI MESAFE | 10395 mm |
| BOJİ TİPİ | Y25Ls(s)d1-K / Y25Lsdi(f) -K |

Technical Characteristics

| | |
|--------------------------------|---------------------------------|
| TRACK GAUGE | 1435 mm |
| TARE WEIGHT WEIGHT | 24,7 t |
| LOADING LOADING CAPACITY | 110,3 t |
| TOTAL WEIGHT | 135 t |
| LENGTH OF WAGON | 25150 mm |
| WIDTH OF WAGON | 3135 mm |
| HEIGHT OF WAGON | 1135 mm |
| LENGTH OVER BUFFERS | 26390 mm |
| DISTANCE BETWEEN BOGIE CENTERS | 10395 mm |
| BOGIE TYPE | Y25Ls(s)d1-K / Y25Lsdi(f) -K |

Hccrrs TYPE CAR CARRYING WAGON

Hccrrs TİPİ ARAÇ TAŞIMA VAGONU



*Dış hava şartlarından etkilenmeden otomobil, hafif ticari araç, SUV, tractor vb. araçların demiryolu ile taşımalarının yapılabilmesine olanak sağlayan çift katlı Hccrrs Tip Araç Taşıma Vagonu; TSI, EN, UIC standartlarının gereksinimlerini karşılar ve TEN GE trafiğine uygundur.

*The double deck Hccrrs Type Vehicle Transport Wagon, which allows the transportation of cars by railways like light commercial cars, SUV, tractor etc. without being affected by external weather conditions; It meets the requirements of TSI, EN, UIC standards and is suitable for TEN GE traffic.





Hecrrs TYPE



Teknik Özellikler

| | |
|---------------------------|---------------------|
| RAY AÇIKLIĞI | 1435 mm |
| DARA AĞIRLIĞI | 38 t |
| YÜKLEME KAPASİTESİ | 34 t |
| TOPLAM AĞIRLIĞI | 72 t |
| ARAÇ KAPASİTESİ | 12 Adet |
| YÜKLEME ALANI | 72,5 m ² |
| VAGON BOYU | 29120 mm |
| VAGON GENİŞLİĞİ | 2890 mm |
| VAGON YÜKSEKLİĞİ | 4570 mm |
| TAMPONDAN TAMPONA UZUNLUK | 31000 mm |

Technical Characteristics

| | |
|---------------------|---------------------|
| TRACK GAUGE | 1435 mm |
| TARE WEIGHT | 38 t |
| LOADING CAPACITY | 34 t |
| TOTAL WEIGHT | 72 t |
| VEHICLE CAPACITY | 12 |
| LOADING SURFACE | 72,5 m ² |
| LENGTH OF WAGON | 29120 mm |
| WIDTH OF WAGON | 2890 mm |
| HEIGHT OF WAGON | 4570 mm |
| LENGTH OVER BUFFERS | 31000 mm |

Rilnss TYPE TENTED WAGON

Rilnss TİPİ TENTELİ VAGON



*Dış hava şartlarından etkilenmeden otomobil, demiryolu ile yük taşımacılığının yapılabilmesine olanak sağlayan Rilnss Tip Tenteli Vagon; TSI, EN, UIC standartlarının gereksinimlerini karşılar ve TEN GE trafiğine uygundur.

*The Rilnss Type Tarpaulin (Tented) Wagon, which allows the transportation of freight by railways without being affected by external weather conditions; It meets the requirements of TSI, EN, UIC standards and is suitable for TEN GE traffic.





Rilnss TYPE



Teknik Özellikler

| | |
|-----------------------------|-------------------|
| RAY AÇIKLIĞI | 1435 mm |
| DARA AĞIRLIĞI | 27 t |
| YÜKLEME KAPASİTESİ | 63 t |
| TOPLAM AĞIRLIĞI | 90 t |
| YÜKLEME BOYU | 18500 mm |
| YÜKLEME ALANI | 40 m ² |
| VAGON BOYU | 19100 mm |
| VAGON GENİŞLİĞİ | 3040 mm |
| PLATFORM YÜKSEKLİĞİ | 1240 mm |
| TAMPONDAN TAMPONA UZUNLUK | 20340 mm |
| BOJİ EKSENLERİ ARASI MESAFE | 15300 mm |
| BOJİ TİPİ | Y25Ls(s)d1-K |

Technical Characteristics

| | |
|--------------------------------|-------------------|
| TRACK GAUGE | 1435 mm |
| TARE WEIGHT | 27 t |
| LOADING CAPACITY | 63 t |
| TOTAL WEIGHT | 90 t |
| LOADING SIZE | 18500 mm |
| LOADING SURFACE | 40 m ² |
| LENGTH OF WAGON | 19100 mm |
| WIDTH OF WAGON | 3040 mm |
| HEIGHT OF WAGON | 1240 mm |
| LENGTH OVER BUFFERS | 20340 mm |
| DISTANCE BETWEEN BOGIE CENTERS | 15300 mm |
| BOGIE TYPE | Y25Ls(s)d1-K |

Eanoss TYPE HIGH SIDE OPEN TOP WAGON

Eanoss TİPİ YÜKSEK KENARLI AÇIK VAGON



*Ağırlıklı olarak kömür, cevher, taş, briket, hurda gibi hava koşullarına dayanıklı dökme yüklerin taşınmasına uygun olan Eanoss tipi yüksek kenarlı açık vagon; TSI, EN, UIC standartlarının gereksinimlerini karşılar ve TEN GE trafiğine uygundur.

*Eanoss type high sided open wagon, which is suitable for the transportation of weather resistance materials mainly of bulk goods such as coal, ore, stone, briquette, scrap; It meets the requirements of TSI, EN, UIC standards and is suitable for TEN GE traffic.





Eanoss TYPE



Teknik Özellikler

| | |
|-----------------------------|---------------------|
| RAY AÇIKLIĞI | 1435 mm |
| DARA AĞIRLIĞI | 25 t |
| YÜKLEME KAPASİTESİ | 65 t |
| TOPLAM AĞIRLIĞI | 90 t |
| YÜKLEME ALANI | 39,4 m |
| KAPASİTE(HACİM) | 82,5 m ³ |
| VAGON BOYU | 14500 mm |
| VAGON GENİŞLİĞİ | 2728 mm |
| VAGON YÜKSEKLİĞİ | 3335 mm |
| TAMPONDAN TAMPONA UZUNLUK | 15740 mm |
| BOJİ EKSENLERİ ARASI MESAFE | 10700 mm |
| BOJİ TİPİ | Y25Ls(s)d1-K |

Technical Characteristics

| | |
|--------------------------------|---------------------|
| TRACK GAUGE | 1435 mm |
| TARE WEIGHT | 25 t |
| LOADING CAPACITY | 65 t |
| TOTAL WEIGHT | 90 t |
| LOADING SURFACE | 39,4 m ² |
| CAPACITY(VOLUME) | 82,5 m ³ |
| LENGTH OF WAGON | 14500 mm |
| WIDTH OF WAGON | 2728 mm |
| HEIGHT OF WAGON | 3335 mm |
| LENGTH OVER BUFFERS | 15740 mm |
| DISTANCE BETWEEN BOGIE CENTERS | 10700 mm |
| BOGIE TYPE | Y25Ls(s)d1-K |

Zacens TYPE 78 m³ TANK WAGON (INTERNAL HEATING)

Zacens TİPİ 78 m³ SARNIÇ VAGONU (ISITMALI)



*Sıvı kimyasal ve petrol gibi ürünlerinin taşımacılığı için tasarlanıp üretilen Zacens tip Tank Vagonu; TSI, EN, UIC standartlarının gereksinimlerini karşılar ve TEN GE trafiğine uygundur.

*Zacens type Tank Wagon designed and manufactured for the transportation of liquid chemicals and petroleum products; It meets the requirements of TSI, EN, UIC standards and is suitable for TEN GE traffic.





◉>>> Zacens TYPE 78 m³ <<<◉

Teknik Özellikler

| | |
|--------------------------|--------------------------------|
| RAY AÇIKLIĞI | 1435 mm |
| YÜKLEME KAPASİTESİ | 65 t |
| DARA AĞIRLIĞI | 24,5 t |
| YÜKLEME HACMİ | 78 m ³ |
| TANK TİPİ | L4BH |
| TASARIM BASINCI | 10 bar |
| MAKSİMUM ÇALIŞMA BASINCI | 3 bar |
| ISITMA | Dıştan (Buhar Sıcaklığı 190°C) |
| BOJİ EKSENLER ARASI | 11200 mm |
| VAGON BOYU | 15000 mm |
| VAGON YÜKSEKLİĞİ | 4292 mm |
| VAGON GENİŞLİĞİ | 3086 mm |
| BOJİ TİPİ | Y25 Lsd(f) -KC1 |
| BOJİ DİNGİLLER ARASI | 1800 mm |

Technical Characteristics

| | |
|----------------------------|------------------------------|
| TRACK GAUGE | 1435 mm |
| LOADING CAPACITY | 65 t |
| TARE WEIGHT | 24,5 t |
| LOADING VOLUME | 78 m ³ |
| TANK TYPE | L4BH |
| DESIGN PRESSURE | 10 bar |
| MAXIMUM OPERATING PRESSURE | 3 bar |
| HEATING | External (Steam Temp: 190°C) |
| WHEEL BASE OF WAGON | 11200 mm |
| LENGTH OF WAGON | 15000 mm |
| WAGON HEIGHT | 4292 mm |
| WAGON WIDTH | 3086 mm |
| BOGIE TYPE | Y25 Lsd(f) -KC1 |
| WHEEL BASE OF BOGIE | 1800 mm |

Talns TYPE ORE WAGON

Talns TİPİ CEVHER VAGONU



*Neme hassas dökme malzemelerin taşınmasında kullanılan ve çift taraflı pnömatik boşaltma sistemine sahip Talns Tipi Vagon; TSI, EN, UIC standartlarının gereksinimlerini karşılar ve TEN GE trafiğine uygundur.

*Talns Type Wagon, which is used for the transportation of moisture-sensitive bulk materials and has a double-sided pneumatic discharge system; It meets the requirements of TSI, EN, UIC standards and is suitable for TEN GE traffic.





Talns TYPE



Teknik Özellikler

| | |
|----------------------|-------------------|
| RAY AÇIKLIĞI | 1435 mm |
| DARA AĞIRLIĞI | 24,3 t |
| KAPASİTE | 65,5 t |
| HACMİ | 79 m ³ |
| BOJİ EKSENLER ARASI | 8460 mm |
| VAGON BOYU | 12260 mm |
| VAGON YÜKSEKLİĞİ | 4235 mm |
| VAGON GENİŞLİĞİ | 3065 mm |
| BOJİ TİPİ | Y25Lsd(f)-KC1 |
| BOJİ DİNGİLLER ARASI | 1800 mm |

Technical Characteristics

| | |
|---------------------|-------------------|
| TRACK GAUGE | 1435 mm |
| TARE WEIGHT | 24,3 t |
| LOADING CAPACITY | 65.5 t |
| VOLUME | 79 m ³ |
| BOGIE AXIS DISTANCE | 8460 mm |
| CHASSIS LENGTH | 12260 mm |
| HEIGHT OF WAGON | 4235 mm |
| WIDTH OF WAGON | 3065 mm |
| BOGIE TYPE | Y25Lsd(f)-KC1 |
| WHEEL BASE OF BOGIE | 1800 mm |

Zags TYPE LPG CARRYING WAGON

Zags TİPİ LPG TAŞIMA VAGONU



*Sıvılaştırılmış hidrokarbonların (LPG) taşınması için tasarlanıp üretilen Zags Tipi Tank Vagonu; RID ve TSI şartlarını ve ilgili EN/UIC standartlarının gereksinimlerini karşılar ve TEN GE trafiğine uygundur.

*Zags Type Tank Wagon is designed and manufactured for transportation of liquefied hydrocarbons (LPG); It meets the RID and TSI regulations and the corresponding EN/UIC standards and is suitable for TEN GE traffic





Zags TYPE



Teknik Özellikler

| | |
|-----------------------------|--------------------|
| RAY AÇIKLIĞI | 1435 mm |
| DARA AĞIRLIĞI | 33 t |
| YÜKLEME KAPASİTESİ | 57 t |
| TOPLAM AĞIRLIĞI | 90 t |
| HACİM | 113 m ³ |
| VAGON BOYU | 16760 mm |
| VAGON GENİŞLİĞİ | 2355 mm |
| VAGON YÜKSEKLİĞİ | 4300 mm |
| TANK ÇAPI | 3080 mm |
| TAMPONDAN TAMPONA UZUNLUK | 18000 mm |
| BOJİ EKSENLERİ ARASI MESAFE | 12100 mm |
| BOJİ TİPİ | Y25Lsd1-K |

Technical Characteristics

| | |
|--------------------------------|--------------------|
| TRACK GAUGE | 1435 mm |
| TARE WEIGHT | 33 t |
| LOADING CAPACITY | 57 t |
| TOTAL WEIGHT | 90 t |
| VOLUME | 113 m ³ |
| LENGTH OF WAGON | 16760 mm |
| WIDTH OF WAGON | 2355 mm |
| HEIGHT OF WAGON | 4300 mm |
| DIAMETER OF TANK | 3080 mm |
| LENGTH OVER BUFFERS | 18000 mm |
| DISTANCE BETWEEN BOGIE CENTERS | 12100 mm |
| BOGIE TYPE | Y25Lsd1-K |

Tadns TYPE MAGNESITE WAGON

Tadns TİPİ MANYEZİT VAGONU



*Kireçtaşı gibi hava koşullarından korunması gereken dökme malzemelerin taşınmasında kullanılan Tadns Tipi Yük Vagonu; TSI, EN, UIC standartlarının gereksinimlerini karşılar ve TEN GE trafiğine uygundur.

*Tadns Type Wagon, which is used transportation of limestone and other bulk stuffs, which require protection from weather conditions; It meets the requirements of TSI, EN, UIC standards and is suitable for TEN GE traffic.





Tadns TYPE



Teknik Özellikler

| | |
|-----------------------------|-------------------|
| RAY AÇIKLIĞI | 1435 mm |
| DARA AĞIRLIĞI | 26,4 t |
| YÜKLEME KAPASİTESİ | 63,6 t |
| KAPASİTE(HACİM) | 76 m ³ |
| TOPLAM AĞIRLIĞI | 90 t |
| VAGON BOYU | 20380 mm |
| VAGON GENİŞLİĞİ | 2120 mm |
| VAGON YÜKSEKLİĞİ | 4273 mm |
| TAMPONDAN TAMPONA UZUNLUK | 21620 mm |
| BOJİ EKSENLERİ ARASI MESAFE | 16580 mm |
| BOJİ TİPİ | Y25Ls(s)d1-K |

Technical Characteristics

| | |
|--------------------------------|-------------------|
| TRACK GAUGE | 1435 mm |
| TARE WEIGHT | 26,4 t |
| LOADING CAPACITY | 63,6 t |
| CAPACITY(VOLUME) | 76 m ³ |
| TOTAL WEIGHT | 90 t |
| LENGTH OF WAGON | 20380 mm |
| WIDTH OF WAGON | 2120 mm |
| HEIGHT OF WAGON | 4273 mm |
| LENGTH OVER BUFFERS | 21620 mm |
| DISTANCE BETWEEN BOGIE CENTERS | 16580 mm |
| BOGIE TYPE | Y25Ls(s)d1-K |

Faccpps TYPE BALLAST WAGON

Faccpps TİPİ BALAST VAGONU



*Faccpps tipi Balast Taşıma ve Serme Vagonu pnömatik ve manuel kullanım olanağı sağlamaktadır.

*Vagon tasarımı ve üretimi TSI, EN, UIC standartlarının gereksinimlerini karşılar ve TEN GE trafiğine uygundur.

*Ballast carrying wagon is used manually and via a pneumatics.

*The wagon design and manufacturing meets the requirements of TSI, EN, UIC standards and has TEN GE marking for traffic operation.





Facpps TYPE



Teknik Özellikler

| | |
|-----------------------------|---------------------|
| RAY AÇIKLIĞI | 1435 mm |
| DARA AĞIRLIĞI | 24,25 t |
| YÜKLEME KAPASİTESİ | 49,8 t (55,75 t) |
| TOPLAM AĞIRLIĞI | 80 t |
| HACİM | 32,5 m ³ |
| VAGON BOYU | 10958 mm |
| VAGON GENİŞLİĞİ | 2630 mm |
| VAGON YÜKSEKLİĞİ | 3680 mm |
| TAMPONDAN TAMPONA UZUNLUK | 12198 mm |
| BOJİ EKSENLERİ ARASI MESAFE | 7198 mm |
| BOJİ TİPİ | Y25Lsd1-K |

Technical Characteristics

| | |
|--------------------------------|---------------------|
| TRACK GAUGE | 1435 mm |
| TARE WEIGHT | 24,25 t |
| LOADING CAPACITY | 49,8 t (55,75 t) |
| TOTAL WEIGHT | 80 t |
| VOLUME | 32,5 m ³ |
| LENGTH OF WAGON | 10958 mm |
| WIDTH OF WAGON | 2630 mm |
| HEIGHT OF WAGON | 3680 mm |
| LENGTH OVER BUFFERS | 12198 mm |
| DISTANCE BETWEEN BOGIE CENTERS | 7198 mm |
| BOGIE TYPE | Y25Lsd1-K |

Habis TYPE COVERED WAGON WITH SLIDING WALL

Habis TİPİ KAYAR DUVARLI KAPALI VAGON



*Alüminyum yan duvarlara sahip, dış hava koşullarına karşı izole olarak yük taşıyan kapalı tip bir vagon olup; TSI, EN, UIC standartlarının gerekliliklerini karşılar ve TEN GE trafiğine uygundur.

*Habis is a covered type wagon having aluminium side walls and carrying freight as isolated against outer weather conditions; it meets the requirements of TSI, EN, UIC standards and is suitable for TEN GE traffic.





Habis TYPE



Teknik Özellikler

| | |
|----------------------|----------|
| RAY AÇIKLIĞI | 1435 mm |
| YÜKLEME KAPASİTESİ | 62 t |
| DARA AĞIRLIĞI | 28 t |
| BOJİ EKSENLER ARASI | 16600 mm |
| VAGON BOYU | 20460 mm |
| VAGON YÜKSEKLİĞİ | 4098 mm |
| VAGON GENİŞLİĞİ | 2590 mm |
| BOJİ TİPİ | Y25Lsd1 |
| BOJİ DİNGİLLER ARASI | 1800 mm |
| CER TERTİBATI | Tip 540 |

Technical Characteristics

| | |
|---------------------|----------|
| TRACK GAUGE | 1435 mm |
| LOADING CAPACITY | 62 t |
| TARE WEIGHT | 28 t |
| BOGIE AXIS DISTANCE | 16600 mm |
| CHASSIS LENGTH | 20460 mm |
| WAGON HEIGHT | 4098 mm |
| WAGON WIDTH | 2590 mm |
| BOGIE TYPE | Y25Lsd1 |
| WHEEL BASE OF BOGIE | 1800 mm |
| DRAW GEAR | Type 540 |

Hbbilnss TYPE SLIDING WALL WAGON

Hbbilnss TİPİ KAYAR DUVARLI VAGON

*Alüminyum ve yüksek yan duvarlara sahip dış hava şartlarından bağımsız yük taşımacılığına olanak sağlayan Hbbilnss tipi kapalı vagonur.

*Hbbilns is a covered type wagon having high aluminium side walls and carrying freight as isolated against outer weather conditions.





Hbbilnss TYPE



Teknik Özellikler

| | |
|------------------------|-----------------------|
| RAY AÇIKLIĞI | 1435 mm |
| YÜKLEME KAPASİTESİ | 28 t |
| DARA AĞIRLIĞI | 17 t |
| YÜKLEME ALANI | 44 m ² |
| VAGON BOYU | 15170 mm |
| VAGON YÜKSEKLİĞİ | 4295 mm |
| VAGON GENİŞLİĞİ | 2900 mm |
| DİNGİLLER ARASI MESAFE | 10000 mm |
| CER TERTİBATI | Tip 540 |
| TAMPON TİPİ | Bilezik Sustalı 32 kj |

Technical Characteristics

| | |
|------------------|-------------------|
| TRACK GAUGE | 1435 mm |
| LOADING CAPACITY | 28 t |
| TARE WEIGHT | 17 t |
| AREA OF LOADING | 44 m ² |
| WAGON LENGTH | 15170 mm |
| WAGON HEIGHT | 4295 mm |
| WAGON WIDTH | 2900 mm |
| DISTANCE OF AXLE | 10000 mm |
| DRAW GEAR | Type 540 |
| BUFFER TYPE | Ringfeder 32 kj |

Uas TYPE SLEEPER CARRYING WAGON

Uas TİPİ TRAVERS TAŞIMA VAGONU

*Uas tipi vagon travers taşımaya elverişlidir.

*Uas type wagon is used for carrying traverse.

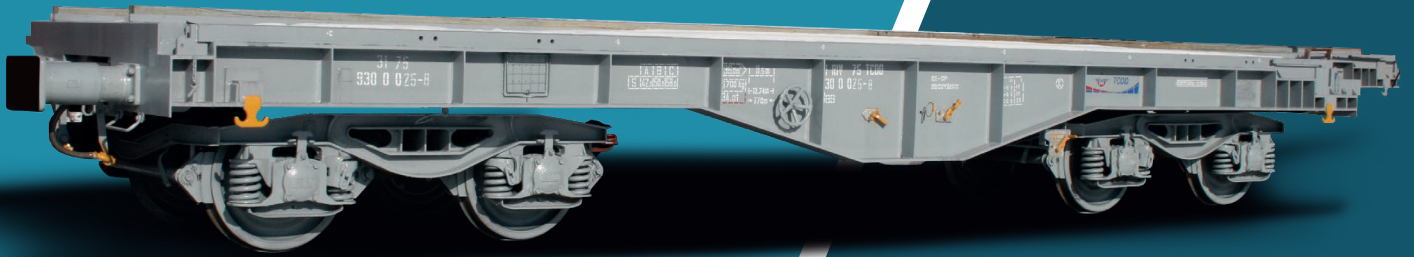

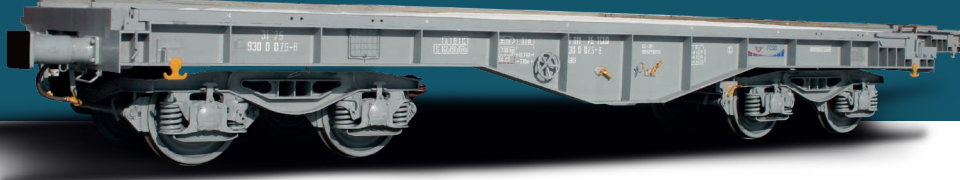

Uas TYPE



Teknik Özellikler

| | |
|----------------------|---------------------------|
| RAY AÇIKLIĞI | 1435 mm |
| YÜKLEME KAPASİTESİ | 57 t |
| DARA AĞIRLIĞI | 23 t |
| YÜKLEME ALANI | 36 m ² |
| BOJİ EKSENLER ARASI | 7700 mm |
| VAGON BOYU | 11500 mm |
| VAGON YÜKSEKLİĞİ | 2175 mm |
| PLATFORM YÜKSEKLİĞİ | 1410 mm |
| VAGON GENİŞLİĞİ | 3174 mm |
| BOJİ TİPİ | Y25 Cs |
| BOJİ DİNGİLLER ARASI | 1800 mm |
| CER TERTİBATI | Bilezik Sustalı (Tip 540) |
| TAMPON TİPİ | Bilezik Sustalı (32 kJ) |

Technical Characteristics

| | |
|---------------------|------------------------|
| TRACK GAUGE | 1435 mm |
| LOADING CAPACITY | 57 t |
| TARE WEIGHT | 23 t |
| AREA OF LOADING | 36 m ² |
| WHEEL BASE OF WAGON | 7700 mm |
| WAGON LENGTH | 11500 mm |
| WAGON HEIGHT | 2175 mm |
| PLATFORM HEIGHT | 1410 mm |
| WAGON WIDTH | 3174 mm |
| BOGIE TYPE | Y25 Cs |
| WHEEL BASE OF BOGIE | 1800 mm |
| DRAW GEAR | Ringfeder (Type 540) |
| BUFFER TYPE | Ringfeder (Type 32 kJ) |

Uadgs TYPE GRAIN CARRYING WAGON

Uadgs TİPİ HUBUBAT TAŞIMA VAGONU

*Uadgs tipi vagon hububat taşımaya elverişlidir.

*Uadgs type wagon is used for carrying cereals.





Uadgs TYPE



Teknik Özellikler

| | |
|----------------------|---------------------------|
| RAY AÇIKLIĞI | 1435 mm |
| YÜKLEME KAPASİTESİ | 55 t |
| DARA AĞIRLIĞI | 25 t |
| HACMİ | 78 m ³ |
| BOJİ EKSENLER ARASI | 10200 mm |
| VAGON BOYU | 15000 mm |
| VAGON YÜKSEKLİĞİ | 4280 mm |
| VAGON GENİŞLİĞİ | 2962 mm |
| BOJİ TİPİ | Y25 Lsd |
| BOJİ DİNGİLLER ARASI | 1800 mm |
| CER TERTİBATI | Bilezik Sustalı (Tip 540) |
| TAMPON TİPİ | Bilezik Sustalı (32 kJ) |

Technical Characteristics

| | |
|---------------------|------------------------|
| TRACK GAUGE | 1435 mm |
| LOADING CAPACITY | 55 t |
| TARE WEIGHT | 25 t |
| VOLUME | 78 m ³ |
| WHEEL BASE OF WAGON | 10200 mm |
| WAGON LENGTH | 15000 mm |
| WAGON HEIGHT | 4280 mm |
| WAGON WIDTH | 2962 mm |
| BOGIE TYPE | Y25 Lsd |
| WHEEL BASE OF BOGIE | 1800 mm |
| DRAW GEAR | Ringfeder (Type 540) |
| BUFFER TYPE | Ringfeder (Type 32 kJ) |

Falns-wu TYPE ORE WAGON

Falns-wu TİPİ CEVHER VAGONU

*Falns-wu tipi vagon
cevher taşımacılığında
kullanılmaktadır.

*Falns-we type wagon is
used for carrying ore





Falns-wu TYPE



Teknik Özellikler

| | |
|----------------------|------------------------------|
| RAY AÇIKLIĞI | 1435 mm |
| YÜKLEME KAPASİTESİ | 67,5 t |
| DARA AĞIRLIĞI | 22,5 t |
| HACMİ | 55 m ³ |
| BOJİ EKSENLER ARASI | 7500 mm |
| VAGON BOYU | 11300 mm |
| VAGON YÜKSEKLİĞİ | 3300 mm |
| VAGON GENİŞLİĞİ | 3100 mm |
| BOJİ TİPİ | Y25Lsd1 |
| BOJİ DİNGİLLER ARASI | 1800 mm |
| CER TERTİBATI | Bilezik Sustalı (Tip 540) |
| TAMPON TİPİ | Bilezik Sustalı (32 kJ) |

Technical Characteristics

| | |
|---------------------|------------------------|
| TRACK GAUGE | 1435 mm |
| LOADING CAPACITY | 67,5 t |
| TARE WEIGHT | 22,5 t |
| VOLUME | 55 m ³ |
| WHEEL BASE OF WAGON | 7500 mm |
| WAGON LENGTH | 11300 mm |
| WAGON HEIGHT | 3300 mm |
| WAGON WIDTH | 3100 mm |
| BOGIE TYPE | Y25Lsd1 |
| WHEEL BASE OF BOGIE | 1800 mm |
| DRAW GEAR | Ringfeder (Type 540) |
| BUFFER TYPE | Ringfeder (Type 32 kJ) |

Gabs TYPE COVERED FREIGHT WAGON

Gabs TİPİ KAPALI YÜK VAGONU

*Dış hava şartlarından bağımsız yük taşımacılığına olanak sağlayan Gabs tipi kapalı vagonudur.

*Gabs is a covered type wagon used for carrying freight as isolated from outer weather conditions.





Gabs TYPE



Teknik Özellikler

| | |
|----------------------|------------------------|
| RAY AÇIKLIĞI | 1435 mm |
| YÜKLEME KAPASİTESİ | 61,5 t |
| DARA AĞIRLIĞI | 28,5 t |
| YÜKLEME ALANI | 52 m ² |
| VAGON BOYU | 20460 mm |
| VAGON YÜKSEKLİĞİ | 4013 mm |
| VAGON GENİŞLİĞİ | 3040 mm |
| BOJİ TİPİ | Y25 Lsd 1 |
| BOJİ DİNGİLLER ARASI | 1800 mm |
| CER TERTİBATI | Tip 540 |
| TAMPON TİPİ | UIC 526-1 (Kategori A) |

Technical Characteristics

| | |
|---------------------|------------------------|
| TRACK GAUGE | 1435 mm |
| LOADING CAPACITY | 61,5 t |
| TARE WEIGHT | 28,5 t |
| AREA OF LOADING | 52 m ² |
| WAGON LENGTH | 20460 mm |
| WAGON HEIGHT | 4013 mm |
| WAGON WIDTH | 3040 mm |
| BOGIE TYPE | Y25 Lsd 1 |
| WHEEL BASE OF BOGIE | 1800 mm |
| DRAW GEAR | Tip 540 |
| BUFFER TYPE | UIC 526-1 (Kategori A) |

RESCUE AND FIRE EXTINGUISHING WAGON

KURTARMA ve YANGIN SÖNDÜRME VAGONU

*Yangın Söndürme ve Kurtarma Vagonu, iki adet 60' Rgns tipi konteyner platform vagonu üzerine iki ayrı kısımdan oluşan bir sistem olarak tasarlanmıştır. Vagonlardan biri üzerinde, çalışma platformlu 20' konteyner içinde yerleştirilmiş dizel tahrikli pompa ünitesi ile 70 kVA dizel tahrikli jeneratör ünitesi; bir adet 20 m³ Su, 4 m³ Köpük içeren toplam 24 m³ lük Su/Köpük Tankı (20'); ve bir adet 24 m³ Su tankından (20') oluşmaktadır. Diğer Vagon ünitesi ise, kurtarma ekipmanlarını ve personel yaşam YÜKLEME ALANINI içeren çalışma platformlu 40' lik konteyner ünitesi ile bir adet 24 m³ Su tankından (20') oluşmaktadır.

*Fire extinguishing and rescue Wagon. It is designed as a system consisting of two sections over two Rgns 60'type container wagon. There is a diesel engine pumping unit and 70 kVA diesel generator unit located in 20' container, a 20 m³ water tank and 24 m³ water/foam tank containing 4 m³ foam and 24 m³ water tank in one section of the wagon. In the other section there is a 40' container unit including rescue equipment and staff living area and a 24 m³ water tank.





RESCUE AND FIRE EXTINGUISHING WAGON



Teknik Özellikler

| | |
|-------|---|
| TANIM | <p>Yangın söndürme ve kurtarma vagonu ile müdahale edilen her türde vagonun ve kazanın;</p> <ul style="list-style-type: none">• Vagon içinde bulunan yük, yolcu ve personelin tehlike anında emniyete alınarak tahliyesi,• Özellikle petrol ve türevlerinin taşınması esnasında yaşanabilecek kazalarda muhtemel deray, yangın, sızıntı, patlama vb. olaylarının önlenmesi ile olası kayıp ve zararların minimuma indirilmesi,• Çevre tedbirlerinin alınarak olası çevre ve doğa zararlarının en aza indirilmesi amaçlanmaktadır. |
|-------|---|

Technical Characteristics

| | |
|----------------------|--|
| PURPOSE OF THE WAGON | <p>All types of wagons and boilers intervened with Fire Extinguishing and Rescue Wagons;</p> <ul style="list-style-type: none">• Safely evacuating the cargo, passengers and personnel in the wagon in case of danger,• Possible derailment, fire, leakage, explosion, etc. in accidents that may occur especially during the transportation of oil and its derivatives. Preventing incidents and minimizing possible losses and damages,• Minimizing possible environmental and natural damages by taking environmental precautions are intended. |
|----------------------|--|

BOGIES

BOJİLER

TURASAS

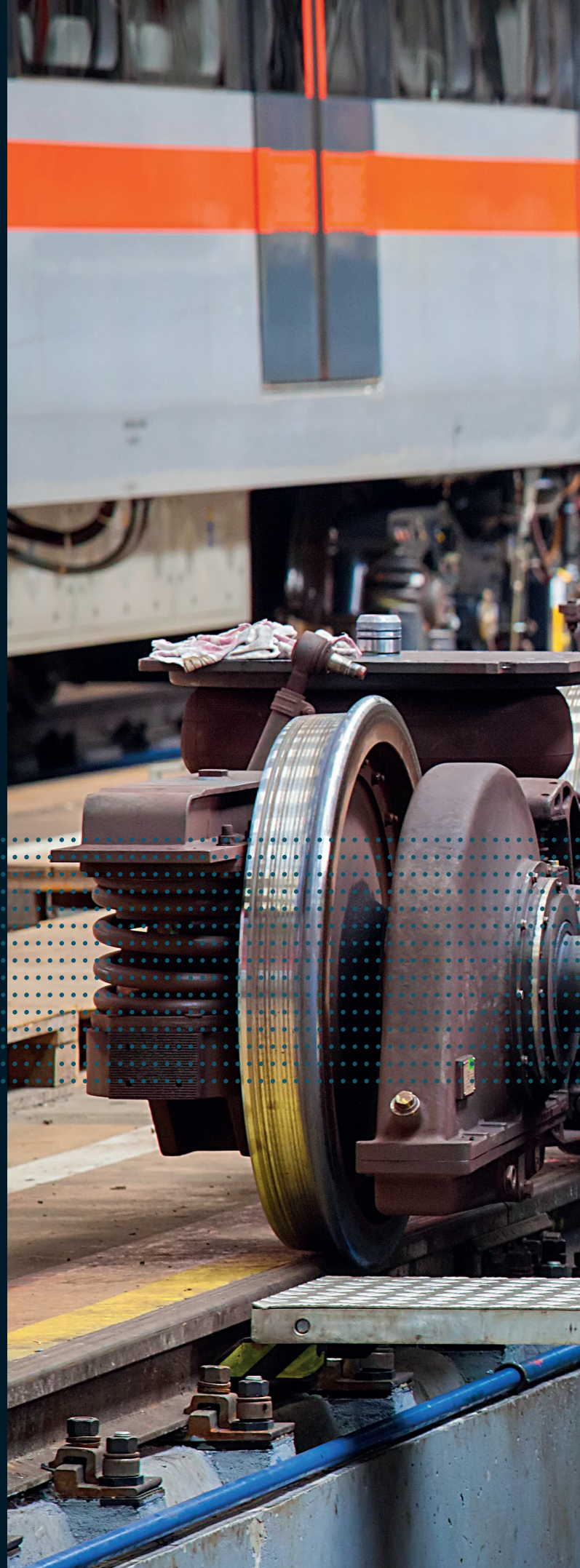



K TYPE COMPOSITE BLOCKS AND DISC PADS

K TİPİ KOMPOZİT BLOK BALATALAR VE DİSK BALATALAR

TURASAS

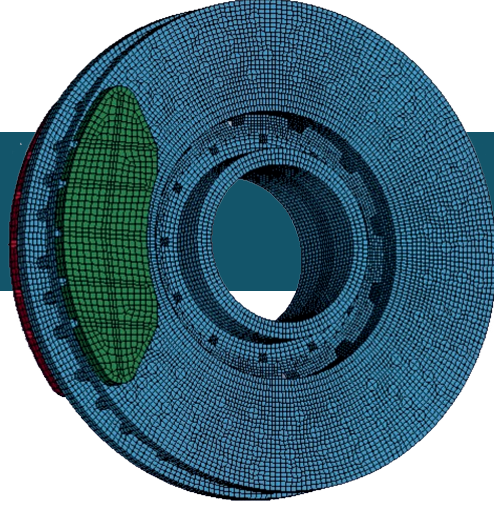

Teknik Özellikler

| | |
|----------------------------|-------------|
| TİP | K tipi |
| MALZEME | Kompozit |
| ASBEST | İçermez |
| ÖMÜR | Uzun Ömürlü |
| SÜRTÜNME KARAKTERİSTİĞİ | Stabil |

Technical Characteristics

| | |
|----------------------------|--------------|
| TYPE | K type |
| MATERIAL | Composite |
| ASBESTOS | Free |
| SERVICE LIFE | Long-Lasting |
| FRICTION CHARACTERISTIC | Stable |



Y25Ls(s)d1-K TYPE BOGIE

Y25Ls(s)d1-K TİPİ BOJİ

TURASAS



Teknik Özellikler

| | |
|--|---------------|
| RAY AÇIKLIĞI | 1435 mm |
| AKS YÜKLEME KAPASİ- | 22,5 t |
| YÜKLEME GÖSTERGESİ | G1-TSI |
| FREN REJİMİ | "s" veya "ss" |
| FREN BLOĞU | K |
| FREN BLOK TUTUCU | Bgu |
| 22,5 TON AKS YÜKLEME KAPASİTESİ İLE MAKSİ- | 100 km/s |
| 20 TON AKS YÜKLEME KAPASİTESİ İLE MAKSİ- | 120 km/s |
| İKLİM KOŞULLARI | T1 |
| DARA AĞIRLIĞI | 4,53 t |

Technical Characteristics

| | |
|---------------------------------------|-------------|
| TRACK GAUGE | 1435 mm |
| AXLE LOAD | 22,5 t |
| LOADING TRACK GAUGE | G1-TSI |
| BRAKE REGIME | "s" or "ss" |
| BRAKE BLOCK | K |
| BRACKE BLOCK HOLDER | Bgu |
| MAXIMUM SPEED WITH 22,5 TON AXLE LOAD | 100 km/h |
| MAXIMUM SPEED WITH 20 TON AXLE LOAD | 120 km/h |
| CLIMATE CONDITION | T1 |
| TARE WEIGHT WEIGHT | 4,53 t |

Y25Ls(s)d1-KP1 TYPE BOGIE

Y25Ls(s)d1-KP1 TİPİ BOJİ

TURASAS

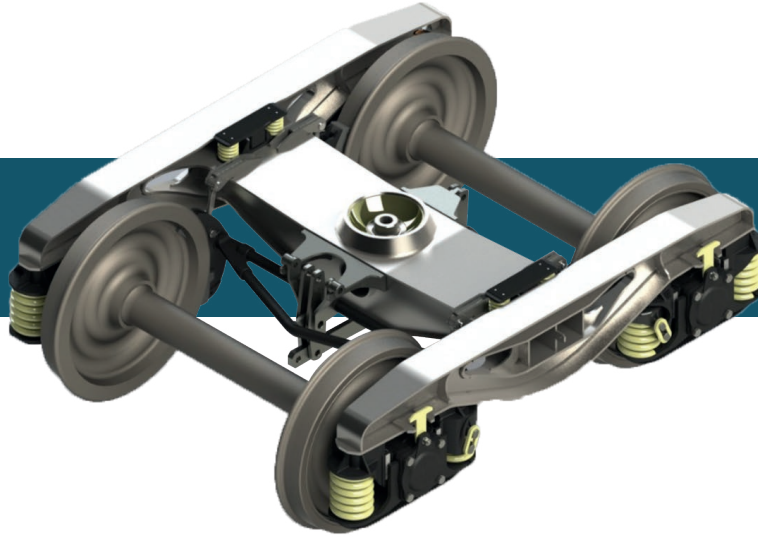

Teknik Özellikler

| | |
|--|---------------|
| RAY AÇIKLIĞI | 1435 mm |
| AKS YÜKLEME KAPASİ- | 22,5 t |
| YÜKLEME GÖSTERGESİ | G1-TSI |
| FREN REJİMİ | "s" veya "ss" |
| FREN BLOĞU | K |
| FREN BLOK TUTUCU | Bgu |
| 22,5 TON AKS YÜKLEME KAPASİTESİ İLE MAKSİ- | 100 km/s |
| 20 TON AKS YÜKLEME KAPASİTESİ İLE MAKSİ- | 120 km/s |
| İKLİM KOŞULLARI | T1 |
| DARA AĞIRLIĞI | 4 t |
| FREN SİSTEMİ TEDARİKÇİSİ | Knorr Bremse |

Technical Characteristics

| | |
|---------------------------------------|--------------|
| TRACK GAUGE | 1435 mm |
| AXLE LOAD | 22,5 t |
| LOADING TRACK GAUGE | G1-TSI |
| BRAKE REGIME | "s" or "ss" |
| BRAKE BLOCK | K |
| BRACKE BLOCK HOLDER | Bgu |
| MAXIMUM SPEED WITH 22,5 TON AXLE LOAD | 100 km/h |
| MAXIMUM SPEED WITH 20 TON AXLE LOAD | 120 km/h |
| CLIMATE CONDITION | T1 |
| TARE WEIGHT WEIGHT | 4 t |
| BRAKE SYSTEM SUPPLIER | Knorr Bremse |

Y25Lsdi(f)-KC1 TYPE BOGIE

Y25Lsdi(f)-KC1 TİPİ BOJİ

TURASAS

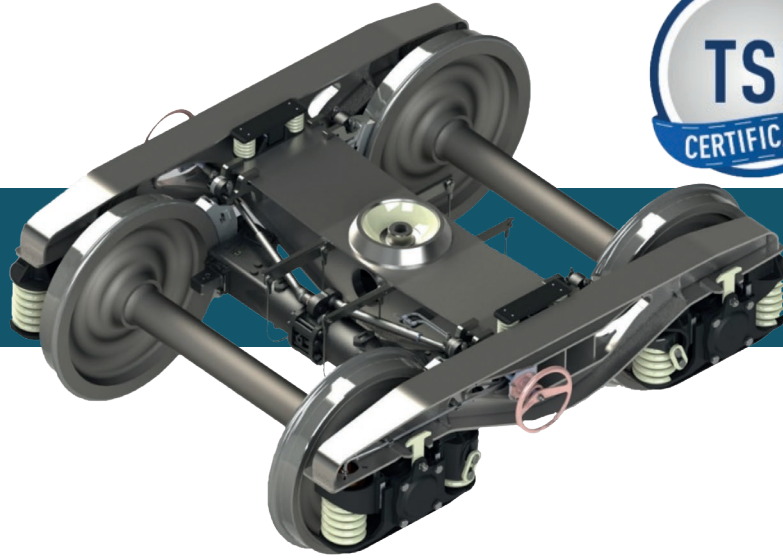

Teknik Özellikler

| | |
|--|--------------|
| RAY AÇIKLIĞI | 1435 mm |
| AKS YÜKLEME KAPASİ- | 22,5 t |
| YÜKLEME GÖSTERGESİ | G1-TSI |
| FREN REJİMİ | S |
| FREN BLOĞU | K |
| FREN BLOK TUTUCU | Bgu |
| 22,5 TON AKS YÜKLEME KAPASİTESİ İLE MAKSİ- | 100 km/s |
| YÜKSÜZ MAKSİMUM HIZ | 120 km/s |
| İKLİM KOŞULLARI | T1 |
| DARA AĞIRLIĞI | 4,2 t |
| FREN SİSTEMİ TEDARİKÇİSİ | Knorr Bremse |

Technical Characteristics

| | |
|---------------------------------------|--------------|
| TRACK GAUGE | 1435 mm |
| AXLE LOAD | 22,5 t |
| LOADING TRACK GAUGE | G1-TSI |
| BRAKE REGIME | S |
| BRAKE BLOCK | K |
| BRACKE BLOCK HOLDER | Bgu |
| MAXIMUM SPEED WITH 22,5 TON AXLE LOAD | 100 km/h |
| MAXIMUM SPEED WITH NO-LOAD | 120 km/h |
| CLIMATE CONDITION | T1 |
| TARE WEIGHT WEIGHT | 4,2 t |
| BRAKE SYSTEM SUPPLIER | Knorr Bremse |

Y32 BOGIE

Y32 BOJİ

TURASAS

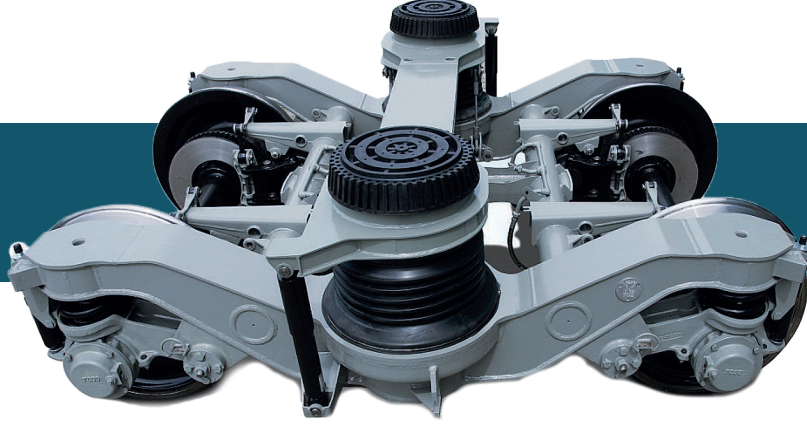

Teknik Özellikler

| | |
|-------------------------|-------------------------------------|
| HIZ | 160 km/s |
| RAY AÇIKLIĞI | 1435 mm |
| FREN SİSTEMİ | Disk Fren |
| TEKERLEK ÇAPI | 920 mm/870 mm |
| TİP | H Tipi Kaynaklı Çelik Konstrüksiyon |
| İKİ DİNGİL ARASI MESAFE | 2560 mm |
| 1.SÜSPANSİYON | Helisel Yay |
| 2.SÜSPANSİYON | Helisel Yay+ Kauçuk |

Technical Characteristics

| | |
|----------------------------|-----------------------------------|
| SPEED | 160 km/s |
| TRACK TRACK GAUGE | 1435 mm |
| BRAKE SYSTEM | Disc Brake |
| WHEEL DIAMETER | 920 mm/870 mm |
| TYPE | H Type Welding Steel Construction |
| DISTANCE BETWEEN WHEELBASE | 2560 mm |
| PRIMARY SUSPENSION | Helicoil Spring |
| SECONDARY SUSPENSION | Helicoil Spring with Rubber |



GENEL MÜDÜRLÜK

Oğuzlar Mahallesi Ceyhun Atuf Kansu Caddesi No:61/1 Balgat
ÇANKAYA/ANKARA/TÜRKİYE
Tel: +90 (312) 202 90 00 / 444 2 887



ESKİŞEHİR BÖLGE MÜDÜRLÜĞÜ

Ahmet Kanatlı Cad. 26 490
ESKİŞEHİR/TÜRKİYE
Tel: +90 (222) 224 00 00 / Fax: +90 (222) 225 72 72



SAKARYA BÖLGE MÜDÜRLÜĞÜ

Milli Egemenlik Cad. Mithatpaşa Mah. No:131 54100
ADAPAZARI/SAKARYA/TÜRKİYE
Tel: +90 (264) 275 16 60 / Fax: +90 (264) 275 16 79



SİVAS BÖLGE MÜDÜRLÜĞÜ

Kadıburhanettin Mah. Fabrika Cad. No: 12
SİVAS/TÜRKİYE
Tel: +90 (346) 225 18 18 / Fax: +90 (346) 223 50 51



T.C. ULAŞTIRMA VE
ALTYAPI BAKANLIĞI

TURASAS