

NOTES:

1. PAINTING – COLOUR AND PROCESS ACC. TO MANUFACTURER'S INSTRUCTION.
2. REMAINING ELEMENTS 4 WELDED THE SAME WAY AS IN THE SECTION VIEW B-B.
3. REMAINING ELEMENTS 2 WELDED THE SAME WAY AS IN THE SECTION VIEW C-C.
4. REMAINING ELEMENTS 6-11 WELDED THE SAME WAY AS IN THE SECTION VIEW B-B.
5. INTERMITTENT WELDS HAVE TO BE FILL.

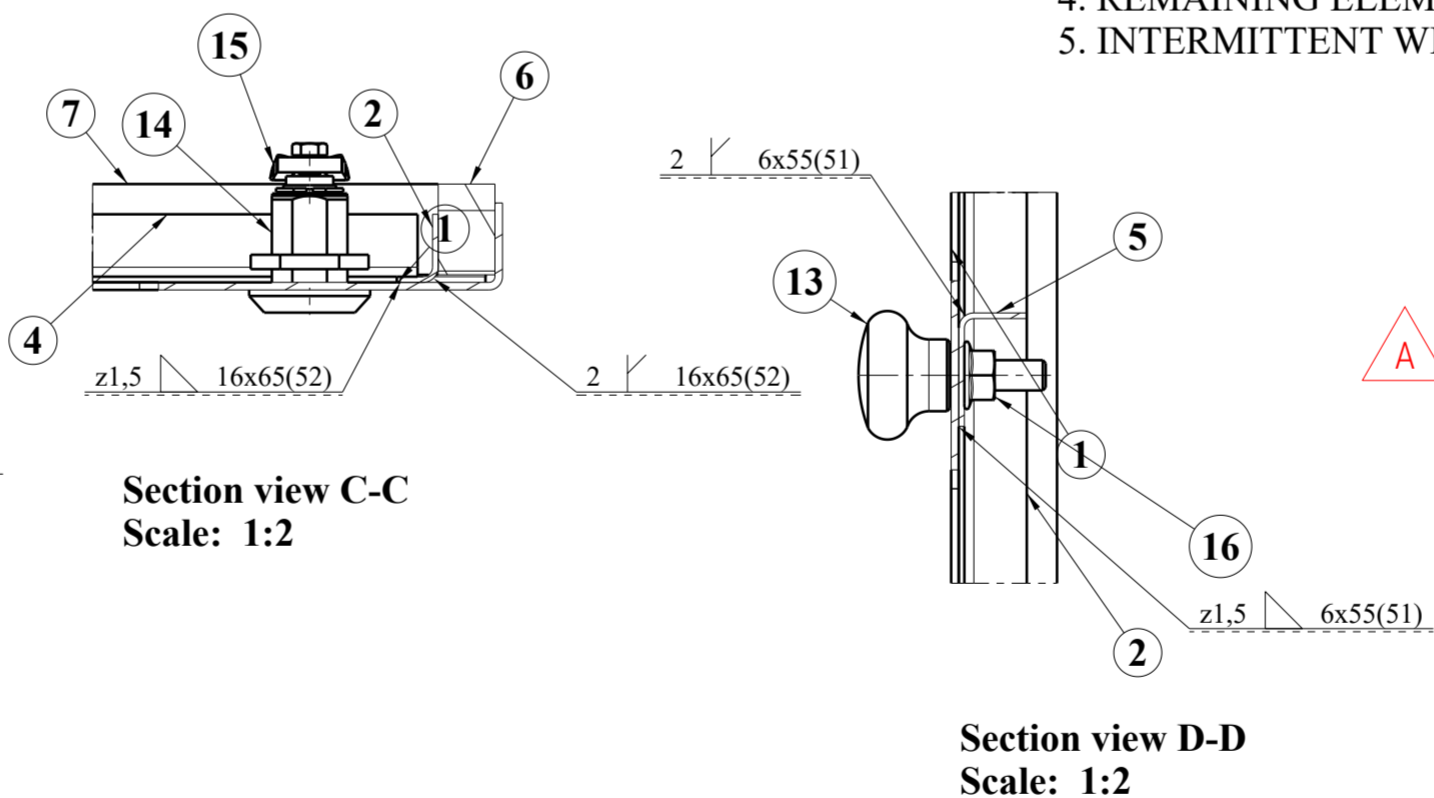

Adet	Parça Adı	Montaj No	Norm/Resim No	Malzeme	Birim Ağırlık(Kg)	Yarı Mamülün Ölçüleri/ Ürün Özellikleri
12	FLANSLI ALTIGEN SOMUN	17	TN1044-00-BA	8	0,002kg	M5
1	FLANSLI ALTIGEN SOMUN	16	TN1044-02-BA	8	0,008kg	M8
2	KILIT DILI	15	TN1105-1108	ASSY	0,027kg	-
2	KARE KILIT GÖVDESİ	14	TB2780-22	-	0kg	-
1	HANDLE	13	TB50045-1	ASSY	0,11kg	xx
3	HINGE	12	TB50044	-	0kg	-
1	GASKET	11	001SC0010093-000	EPDM	0,012kg	xx
1	GASKET	10	001SC0010092-000	EPDM	0,402kg	xx
2	GASKET	9	001SC0010091-000	EPDM	0,405kg	xx
1	GASKET	8	001SC0010090-000	EPDM	0,043kg	xx
2	GASKET	7	001SC0010071-000	EPDM	0,321kg	xx
1	GASKET	6	001SC0010070-000	EPDM	0,925kg	xx
1	ANGLE	5	001SC0010069-000	S355J2+N	0,313kg	xx
2	ANGLE	4	001SC0010068-000	S355J2+N	0,176kg	xx
1	ANGLE	3	001SC0010067-000	S355J2+N	0,511kg	xx
1	ANGLE	2	001SC0010066-000	S355J2+N	0,538kg	xx
1	DOOR	1	001SC0010065-000	S355J2+N	9,717kg	xx

Bu çizim kritik kalite parametresi içerir mi?Hayır		Kritik kalite parametresi şu şekilde gösterilmiştir. <input checked="" type="checkbox"/>	
Grup No:		Toplam Ağırlık (Kg): 14,716	
Tip	Tadilat	Toleransı verilmeyen ölçüler için ilgili standartlar: EN 13920 BBF (Kaynaklı yapılar) EN 22768-1m (Uzunluk ve açı ölçüleri) EN 22768-2 K (Şekil ve Konumlar)	
Resim	R.MEKSULA	02.09.2021	Onay: T.EROGLU
Kontrol	A.PATLAK	09.09.2021	Tarih: 16.09.2021
Ky Müh.	S.ÇÖKMEZ	09.09.2021	
Kaynak Parametresi	15085-2 CL 2	CP C2 CT 3	
Ölçek	1:5	Kağıt Ebadı A2	SWITCH GEAR CUBICLE DOOR, WELDED
			TÜRASAŞ Türkiye Raylı Sistem Araçları Sanayii A.Ş. Eskişehir Bölge Müdürlüğü
			den proje
			Bu yerine geçti.
			Komple Resim/Poz No
			001SC0010002-000

101	z1,5 weld	EN ISO 14341-A-G 46 4	CP C2
100	2HY weld	EN ISO 14341-A-G 46 4	CP C2
No.	Weld type	Welding consumables	Weld class

B	Changed thickness of pos. 1	17.02.2025	K.Karnasiewicz
A	Added TB numbers for handle and hinges	07.04.2022	M.Pudlo
Rev.	Description	Data	Author

