

Unfolded view
Scale: 1:2

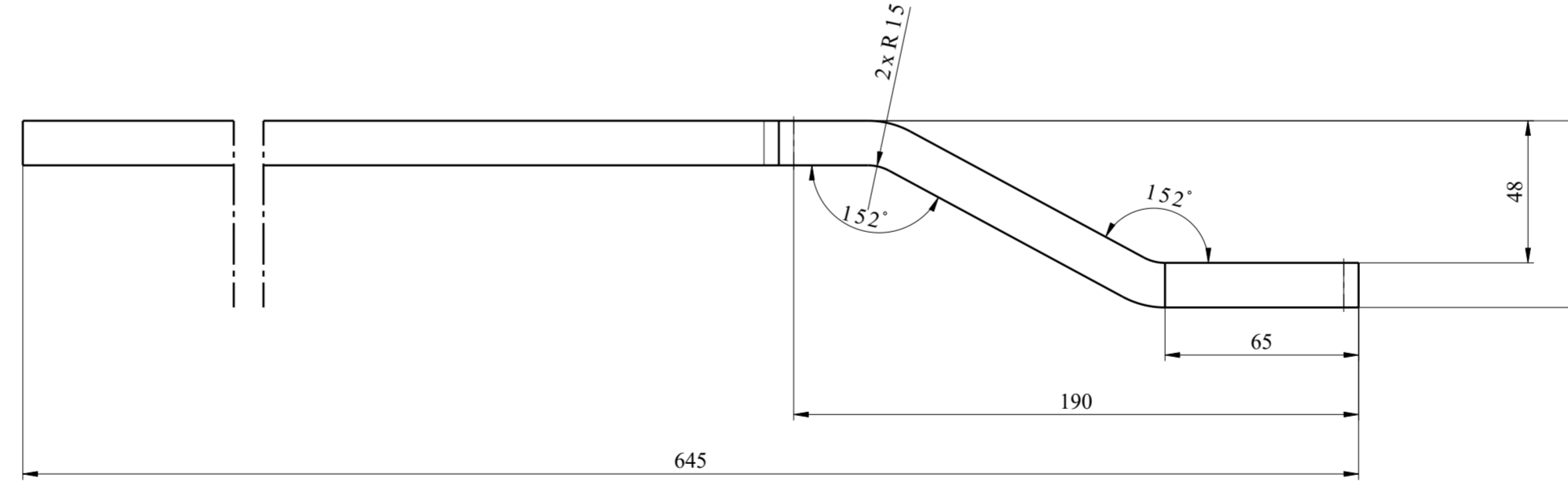

Rev.	Description	Data	Author
C	Added unfolded view	16.10.2025	
B	Part reshaping	06.12.2022	K.Dzikowski
A	Changed holes size and position	12.04.2022	M.Cieśla

Adet	Parça Adı	Standart No	Malzeme	Birim Ağırlık Kg	Yarı Mamülün Ölçüleri
	Busbar	N/A	Cu-ETP	3,443	xx
Bu çizim kritik kalite parametresi içerir mi? Hayır <input type="checkbox"/> Kritik kalite parametresi şu şekilde gösterilmiştir. <input checked="" type="checkbox"/>					
Grup No:		Tasnif No:		Toleransı verilmeyen ölçüler için ilgili standartlar: EN 13920 BBF (Kaynaklı yapılar) EN 22768-1m (Uzunluk ve açı ölçüleri) EN 22768-2 K (Şekil ve Konumlar)	
Tip		C Updated		16.10.2025	
Resim		K.DZIKOWSKI		06.12.2022	
Kontrol		A.PATLAK		20.09.2021	
Ky Müh.					
Ölçek		1:2		Kağıt Ebadı A2	
Busbar				TÜRASAŞ Türkiye Raylı Sistem Araçları Sanayii A.Ş. Eskişehir Bölge Müdürlüğü den proje Bu yerine geçti. Komple Resim/Poz No 001CB0030007-000	

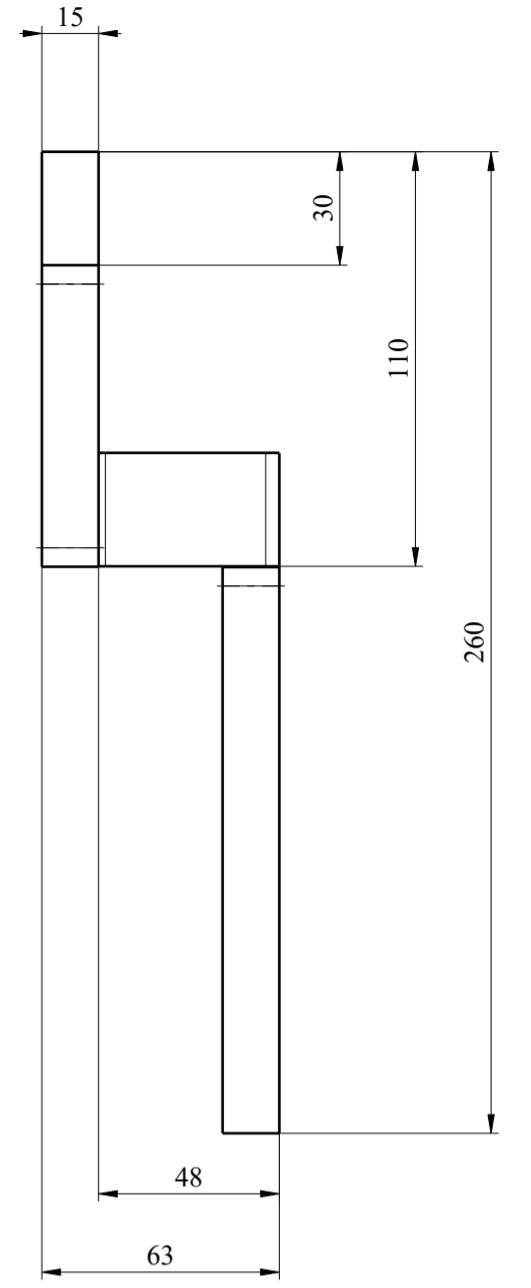
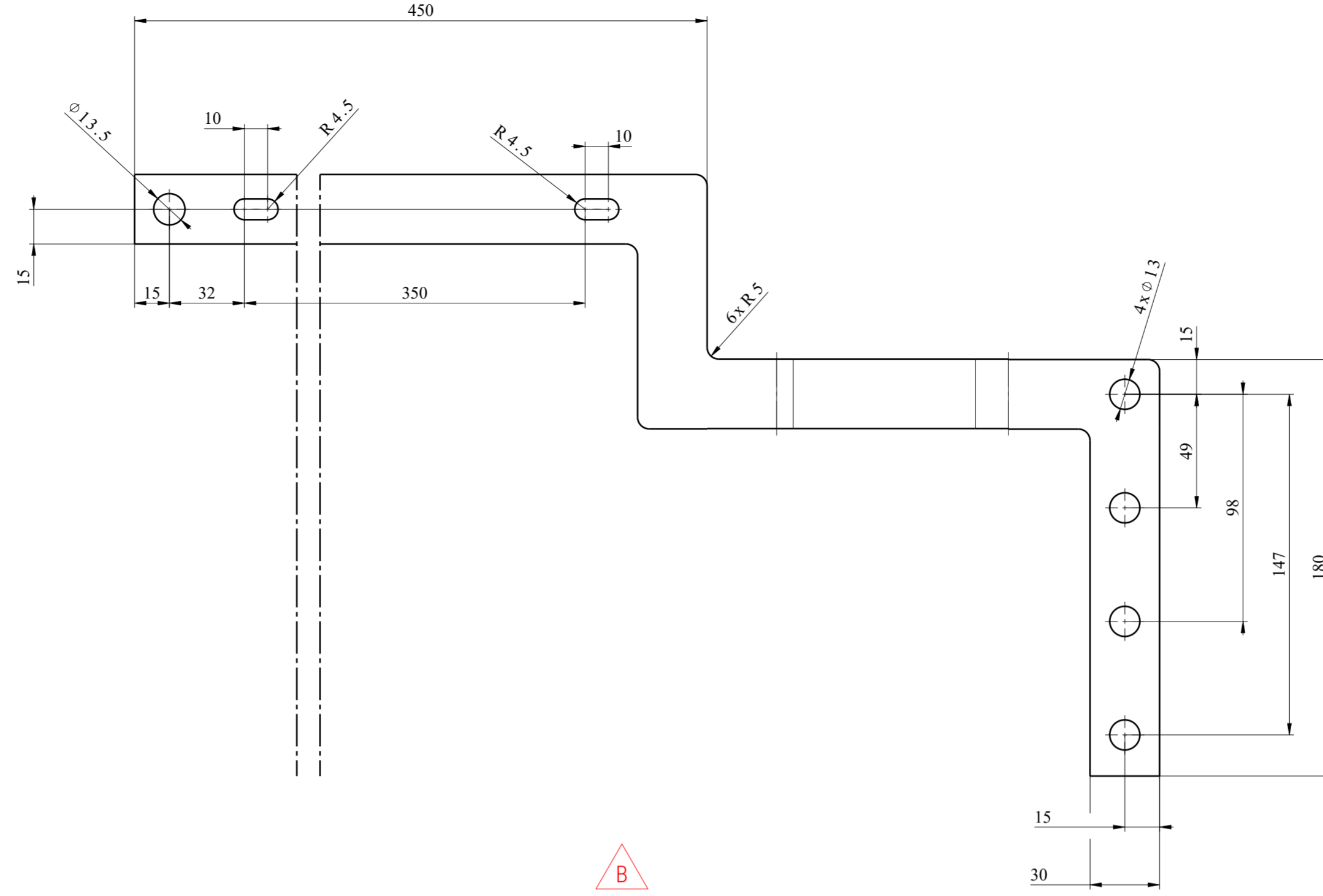