

Section view A-A
Scale: 1:5

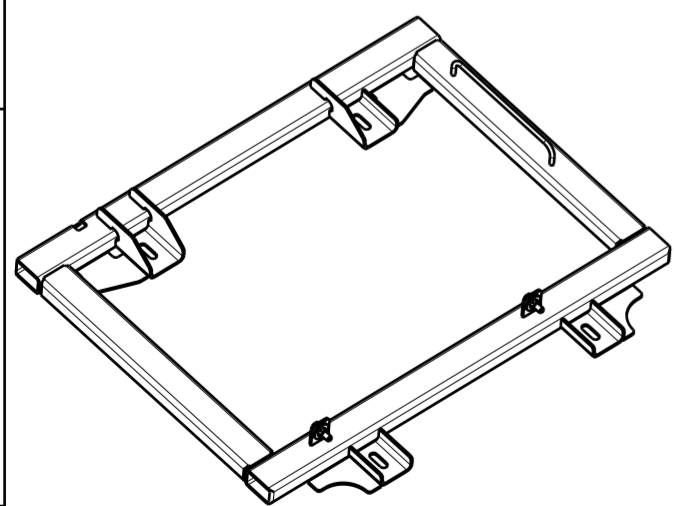

Isometric view

103	a3 weld	EN ISO 14341-A-G 46 4	CP C2
102	2HY weld	EN ISO 14341-A-G 46 4	CP C2
101	3HY weld	EN ISO 14341-A-G 46 4	CP C2
100	3HV weld	EN ISO 14341-A-G 46 4	CP C2
No.	Weld type	Welding consumables	Weld class

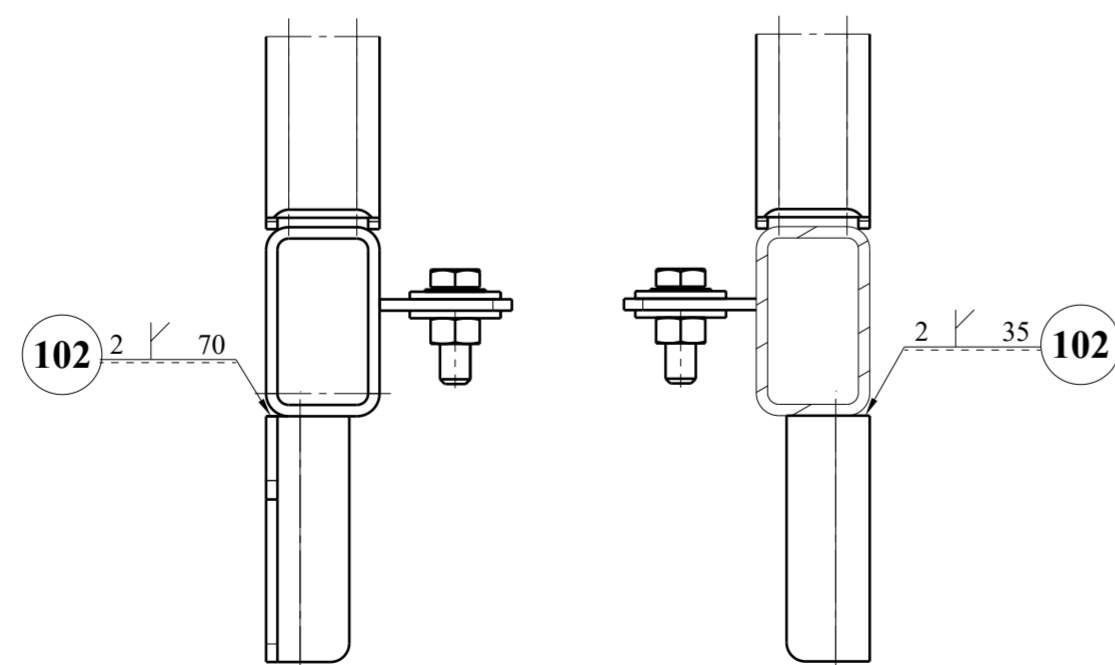

Section view E-E
Scale: 1:2

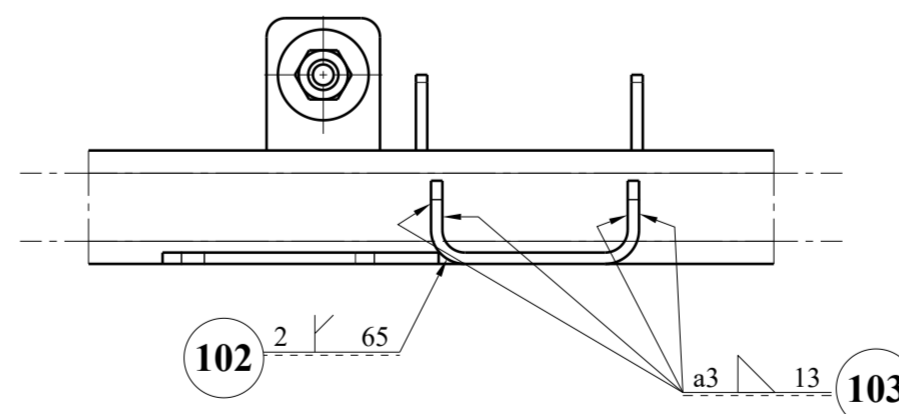

Section view C-C
Scale: 1:2

B	Add welding pos.6-11	12.01.2025	P.Chachlica
A	Pos. 5 quantity changed	19.11.2024	P.Chachlica
Rev.	Description	Data	Author

NOTES:

1. REMAINING ELEMENTS 1, 2, 3 WELDED THE SAME WAY AS IN THE LEFT VIEW.
2. THE WELDING OF PARTS NUMBERED 5 WILL BE DONE THE SAME WAY.

Adet	Parça Adı	Montaj No	Norm/Resim No	Malzeme	Birim Ağırlık(Kg)	Yarı Mamülün Ölçüleri/ Ürün Özellikleri
2	PLATE	10	001CB0010065-000	-	0kg	xx
2	BRACKET	9	001CB0010063-000	-	0kg	xx
2	PLATE	8	001CB0010062-000	-	0kg	xx
1	MOUNTING BRACKET	7	001CB0010061-000	-	0kg	xx
1	MOUNTING BRACKET	6	001CB0010060-000	-	0kg	xx
2	GROUNDING PLATE, ASSY, M8	5	001ME9900520-000	-	0kg	xx
1	WIRE SUPPORT, 200 MM	4	001ME9900014-000	-	0kg	xx
2	RECTANGULAR BEAM	3	001CB0010007-000	-	0kg	xx
1	RECTANGULAR BEAM	2	001CB0010008-000	-	0kg	xx
1	RECTANGULAR BEAM	1	001CB0010059-000	-	0kg	xx

Bu çizim kritik kalite parametresi içerir mi? Hayır Kritik kalite parametresi şu şekilde gösterilmiştir. CTQ

Grup No:		Toplam Ağırlık (Kg): 1,794		TÜRASAŞ	
Tip	Tadilat	Toleransı verilmeyen ölçüler için ilgili standartlar: EN 13920 BBF (Kaynaklı yapılar) EN 22768-1m (Uzunluk ve açılı ölçüleri) EN 22768-2 K (Şekil ve Konumlar)		Türkiye Raylı Sistem Araçları Sanayii A.Ş. Eskişehir Bölge Müdürlüğü	
E5000	Resim	M.PUDLO	23.06.2022	Onay: T.EROGLU	
	Kontrol	A.PATLAK	30.06.2022	Tarih: 30.06.2022	
	Ky Müh.				
	Kaynak Parametresi			TOP FRAME, WELDED	
Ölçek	1:5	Kağıt Ebadı	A2	001CB0014000-000	

NOTES:

1. REMAINING ELEMENTS 1, 2, 3 WELDED THE SAME WAY AS IN THE LEFT VIEW.
2. THE WELDING OF PARTS NUMBERED 5 WILL BE DONE THE SAME WAY.

1	12.01.2025	P.Chachlica
ed	19.11.2024	P.Chachlica
	Data	Author



103	a3 weld	EN ISO 14341-A-G 46 4	CP C2
102	2HY weld	EN ISO 14341-A-G 46 4	CP C2
101	3HY weld	EN ISO 14341-A-G 46 4	CP C2
100	3HV weld	EN ISO 14341-A-G 46 4	CP C2
No.	Weld type	Welding consumables	Weld class